

CANADIAN PATHFINDER ORGANISATION



MANUAL OF DRILL AND CEREMONIAL

THIS PAGE INTENTIONALLY BLANK

TABLE OF CONTENTS

	PAGE
CHAPTER 1: INTRODUCTION	1-1
Purpose.....	1-1
Drill Standards	1-1
Terminology	1-1
Subordination of Illustrations	1-1
Basic Skills.....	1-1
Words of Command.....	1-2
Standard Pause	1-4
Drill Timing.....	1-4
Instructional Techniques.....	1-4
Mechanical Training Aids.....	1-5
Procedures for Conducting a Drill Lesson.....	1-5
CHAPTER 2: SQUAD DRILL AT THE HALT	2-1
Formation of a Squad	2-1
Ordering a Squad on Parade.....	2-2
Dismissing a Squad	2-2
Position of Attention.....	2-3
Position of Stand at Ease	2-4
Position of Stand Easy.....	2-4
Stand at Ease from Attention.....	2-4
Stand Easy from Stand at Ease.....	2-5
Stand at Ease From Stand Easy	2-5
Attention from Stand at Ease.....	2-6
Remove Headdress	2-6
Stand at Ease with Headdress Removed.....	2-7
Stand Easy with Headdress Removed	2-8
Replace Headdress	2-8
Saluting at the Halt	2-8
Turning and Inclining	2-9
Closing to the Right and Left	2-11
Paces Forward and to the Rear.....	2-12
Dressing a Squad	2-13
Open Order March.....	2-14
Close Order March	2-15
Carrying of Objects	2-15
Proving.....	2-15
Numbering	2-16
Calling the Roll.....	2-16
Falling Out of Ranks	2-16
Falling In	2-17
Sizing and Reforming in Three Ranks.....	2-19
Sizing and Reforming in Two Ranks	2-19
Sizing in One Rank and Reforming in Three Ranks (Optional).....	2-20
Forming Two Ranks from Three Ranks (Optional).....	2-21
Reforming Three Ranks from Two Ranks (Optional)	2-22
CHAPTER 3 SQUAD DRILL AT THE HALT	3-1
Fundamentals	3-1
Pace Lengths and Cadences.....	3-1
Words of Command.....	3-1
Marching and Halting in Quick Time.....	3-2
Marching and Halting in Slow Time	3-4
Marching and Halting in Double Time	3-6

Stepping Out and Stepping Short.....	3-7
Mark Time, Forward and Halt from the Mark Time in Quick Time	3-7
Mark Time, Forward and Halt from the Mark Time in Slow Time	3-9
Wheeling.....	3-10
Changing Individual Step on the March	3-11
Changing Step as a Unit on the March (Optional).....	3-12
Changing Step when Marking Time	3-13
Forming a Hollow Square	3-13
Saluting on the March.....	3-14
Paying Unit Compliments on the March	3-16
Turning and Inclining to the Right (Left) on the March in Quick Time	3-16
Turning and Inclining to the Right (Left) on the March in Slow Time	3-17
Turning About on the March in Quick Time.....	3-19
Turning About on the March in Slow Time	3-20
Changing to Slow Time from Quick Time	3-22
Changing to Quick Time from Slow Time	3-22
Changing to Double time from Quick Time	3-22
Changing to Quick Time from Double Time	3-22
Changing Direction by Forming from the Halt (Optional)	3-22
Forming Squad in Line from the Halt (Optional).....	3-24
Forming Squad in Line on the March (Optional)	3-26
Squad in Threes or Twos Forming Single File from the Halt (Optional).....	3-26
Squad in Threes or Twos Forming Single File on the March (Optional)	3-27
Squad in Single File Reforming Threes or Twos from the Halt (Optional)	3-27
Squad in Single File Reforming Threes or Twos on the March (Optional).....	3-27
Squad in Line Forming Single File from the Halt (Optional).....	3-29
Squad in Line Forming Single File on the March (Optional)	3-29
Squad in Single File Reforming in Line from the Halt (Optional).....	3-29
Squad in Single File Reforming in Line on the March (Optional)	3-29
Open Order on the March in Slow Time (Optional).....	3-31
Close Order on the March in Slow Time (Optional).....	3-31
CHAPTER 4: COLOUR DRILL	4-1
General	4-1
Position of the Order.....	4-1
Stand at Ease from the Order.....	4-1
Stand Easy from Stand at Ease	4-2
Stand at Ease from Stand Easy	4-2
Order from Stand at Ease.....	4-2
Carry from the Order	4-3
Order from the Carry	4-3
Let Fly from the Carry.....	4-4
Catch from the Let Fly	4-5
Slope from the Carry	4-6
Carry from the Slope	4-9
GLOSSARY	i

LIST OF FIGURES

	PAGE
CHAPTER 1: INTRODUCTION	
Figure 1-1: Changing Direction and Directing Flanks.....	1-3
CHAPTER 2: SQUAD DRILL AT THE HALT	
Figure 2-1: Squad Formations.....	2-1
Figure 2-2: Position of Attention.....	2-3
Figure 2-3: Position of Stand at Ease from Attention.....	2-4
Figure 2-4: Position of Stand Easy from Stand at Ease.....	2-5
Figure 2-5: Position of Remove Headdress.....	2-6
Figure 2-6: Positions of Stand at Ease and Stand Easy with Headdress Removed.....	2-7
Figure 2-7: Saluting at the Halt.....	2-9
Figure 2-8: Right Turn.....	2-10
Figure 2-9: About Turn.....	2-11
Figure 2-10: Dressing a Squad.....	2-13
Figure 2-11: Open Order March.....	2-15
Figure 2-12: Falling In and Out of Ranks.....	2-17
Figure 2-13: Sizing and Reforming in Three Ranks.....	2-18
Figure 2-14: Sizing in One Rank and Reforming in Threes.....	2-20
CHAPTER 3: SQUAD DRILL ON THE MARCH	
Figure 3-1: Marching in Quick Time.....	3-2
Figure 3-2: Halting in Quick Time.....	3-3
Figure 3-3: Marching in Slow Time.....	3-4
Figure 3-4: Halting in Slow Time.....	3-5
Figure 3-5: Marching in Double Time.....	3-6
Figure 3-6: Marking Time in Quick Time.....	3-8
Figure 3-7: Marking Time in Slow Time.....	3-9
Figure 3-8: Wheeling.....	3-10
Figure 3-9: Changing Individual Step in Quick Time.....	3-11
Figure 3-10: Changing Step as a Unit in Quick Time.....	3-12
Figure 3-11: Changing Step as a Unit in Slow Time.....	3-13
Figure 3-12: Forming a Hollow Square.....	3-14
Figure 3-13: Saluting on the March.....	3-15
Figure 3-14: Right Turn in Quick Time.....	3-17
Figure 3-15: Right Turn in Slow Time.....	3-18
Figure 3-16: About Turn in Quick Time.....	3-19
Figure 3-17: About Turn in Slow Time.....	3-21
Figure 3-18: Right Form at the Halt.....	3-23
Figure 3-19: Forming Squad in Line from the Halt.....	3-25
Figure 3-20: Squad in Threes Forming Single File.....	3-26
Figure 3-21: Squad in Line Forming Single File.....	3-28
Figure 3-22: Squad in Single File Reforming Line from the Halt.....	3-30
CHAPTER 4: COLOUR DRILL	
Figure 4-1: Position of the Order.....	4-1
Figure 4-2: Stand at Ease from the Order.....	4-1
Figure 4-3: Carry from the Order.....	4-2
Figure 4-4: Order from the Carry.....	4-4
Figure 4-5: Let Fly from the Carry.....	4-5
Figure 4-6: Catch from the Let Fly.....	4-6
Figure 4-7: Slope from the Carry.....	4-7
Figure 4-8: Carry from the Slope.....	4-8

THIS PAGE INTENTIONALLY BLANK

CHAPTER 1

INTRODUCTION

PURPOSE

1. This manual establishes uniformity of drill and ceremonial throughout the Canadian Pathfinder organisation and shall be followed on all occasions where drill and ceremonial are carried out.

DRILL STANDARDS

2. The information contained herein is drawn from the Canadian Forces Manual of Drill and Ceremonial. Where necessary, the drill has been modified to suit the unique circumstances of the Pathfinder organisation.
3. Drill is composed of standard body positions and movements completed in response to specific words of command; e.g., ATTENTION or QUICK – MARCH. Therefore, no deviations from the standards are allowed, unless specifically mentioned in this manual, to ensure that the Canadian Pathfinder organisation drills as a single entity.
4. Drill movements identified as optional are included in this manual for advanced drill instruction. The remaining movements are mandatory and all members of the Canadian Pathfinder organisation are expected to become proficient in their usage and execution.

TERMINOLOGY

5. In this manual, "shall", "will", "is" and "are" shall be understood to mean mandatory, and "may" to mean voluntary.
6. Words imparting a masculine gender, such as "he" and "his", are used throughout this manual for simplicity.
7. Key terms used in this manual are listed and defined in a glossary appendix.

SUBORDINATION OF ILLUSTRATIONS

8. The diagrams and illustrations in this manual are intended as supplementary materials to aid instructors' understanding of the execution of drill movements. Where the diagrams and illustrations seemingly conflict with written instructions, the instructions shall be taken as correct.

BASIC SKILLS

9. The four basic movements of drill are:
- (1) Bending the right (left) knee. One leg is braced with the foot firm and flat on the ground maintaining balance with the foot and ankle. The opposite knee is bent and leg raised so that the thigh is parallel to the ground. The bent leg is relaxed so that the lower leg forms a right angle with the thigh, and the foot hangs loosely with the toes pointed downward at a natural angle.
 - (2) Straightening the right (left) leg. The leg is straightened by forcing the toe downward so that the toe of the foot strikes the ground first followed by the heel.
 - (3) Shooting the right (left) foot forward (backward). One leg is kept braced with the foot on the ground while the other foot is shot forward or backward, straight-legged, ready to carry the weight of the body.
 - (4) Shifting the weight. Body weight is shifted by transferring the weight onto one foot while maintaining balance with the foot and ankle of the supporting leg.
10. The phrase "Place the foot flat on the ground" means place the foot naturally on the ground without stomping or exaggeration.

WORDS OF COMMAND

11. Good drill depends on properly delivered words of command, pronounced clearly, distinctly, and with confidence and determination, since these words convey orders that are to be promptly obeyed.

12. Words of command are divided into:

- (1) cautionary commands
- (2) executive commands

13. The cautionary command warns of the movement to be performed and is given first. The cautionary command may include additional instructions such as ADVANCE, RETIRE, etc. The executive command serves as the signal for the movement to be carried out. Throughout this manual, words of command are printed in capital letters. A dash separates the cautionary from the executive portion of the command; e.g., ATTEN – TION.

14. The interval between the cautionary and executive commands should be as long as the standard pause whereas the cautionary command should be called out over a period not less than the standard pause.

15. AS YOU WERE shall be used to order a squad to a previous position or to cancel an incorrect order before the order has been completed.

16. The following are examples of correct words of command:

- (1) SQUAD, MOVE TO THE RIGHT IN THREES, RIGHT – TURN
- (2) PLATOON, BY THE LEFT, QUICK – MARCH
- (3) PARADE, GENERAL SALUTE, SALUTE

17. Squads form up in line with the front, rear, left, and right staying the same (e.g. the front is the direction the squad faces upon falling in and is always the front regardless of which way the squad turns) until the squad is dismissed. The cautionary commands ADVANCE, RETIRE, MOVE TO THE LEFT, and MOVE TO THE RIGHT indicate a turn or movement in the direction of the front, rear, left, and right, respectively. When turning or moving into line the cautionary command IN LINE is used. For turns or movements into file, the cautionary commands are IN FILE, IN TWOS, or IN THREES, depending on whether the squad is turning into one, two, or three files (Figure 1-1). When the result of a turn or incline puts a squad at a 45 degree angle to either the front or rear the cautionary command DIAGONAL MARCH is used. Examples of orders incorporating these commands are:

- (1) SQUAD, MOVE TO THE RIGHT IN THREES, RIGHT – TURN, for a squad in line facing the front and turning to the right into three files
- (2) SQUAD, RETIRE IN LINE, RIGHT – TURN, for a squad in three files facing the right and turning to the rear
- (3) SQUAD, MOVE TO THE RIGHT IN TWOS, ABOUT – TURN, for a squad in two files facing the left and turning to the right
- (4) SQUAD, ADVANCE IN LINE, LEFT – TURN, for a squad facing the right and turning to the front
- (5) SQUAD, DIAGONAL MARCH, RIGHT IN – CLINE, for a squad in threes or in line and inclining right.
- (6) SQUAD, MOVE TO THE RIGHT IN FILE, LEFT IN – CLINE, for a squad in diagonal march and turning to the right in single file

18. After each change of direction on the march the directing flank is indicated by the order BY THE LEFT or BY THE RIGHT, the directing flank normally being the side on which the marker is located.

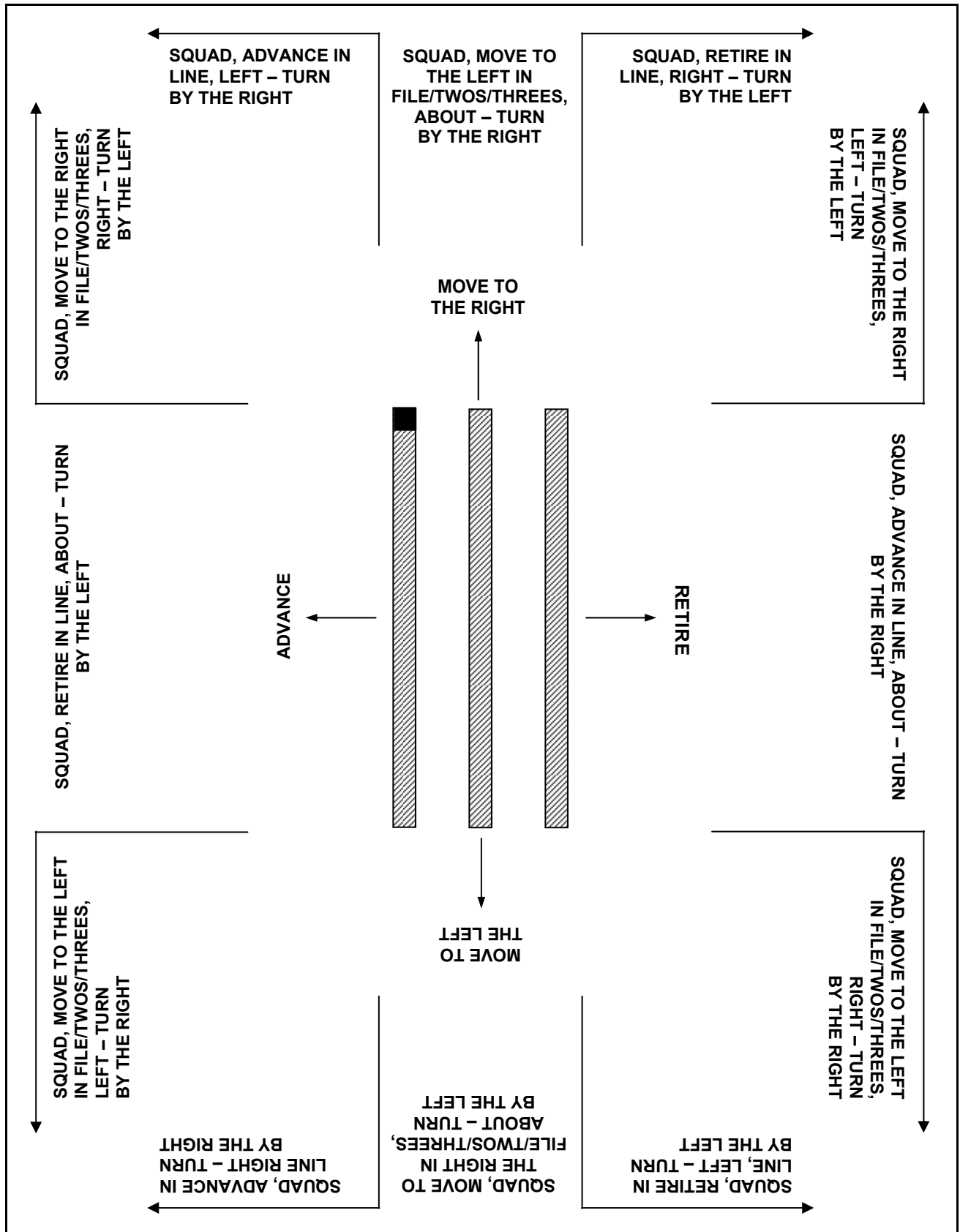

Figure 1-1: Changing Direction and Directing Flanks

STANDARD PAUSE

19. The standard pause between each drill movement is two marching paces at quick time, which equals 1 second (1/2 second per pace * 2 paces).

DRILL TIMING

20. In the early stages of training, the squad shall call out the time when executing drill movements.

21. To warn the squad that the time is to be called out, the instructor will preface a drill movement with the cautionary command CALLING OUT THE TIME. For example, on the command CALLING OUT THE TIME, RIGHT – TURN, the squad:

- (1) executes the first movement of the turn while calling out "ONE"
- (2) calls "TWO – THREE" while observing the standard pause
- (3) calls out "ONE" while executing the final movement

22. Upon commencing to march, and after completing a movement on the march, trainees shall call the step for three paces; i.e. "LEFT – RIGHT – LEFT".

INSTRUCTIONAL TECHNIQUES

23. General. The instructor must continually work to improve the standard of instruction. The techniques described in this section shall be adhered to, thus ensuring the success of drill instruction.

24. Instructor's Appearance and Bearing. Since example is imitated, the instructor's appearance and bearing must be of the highest standard. When conducting drill instruction, the instructor shall stand at attention unless it is necessary to demonstrate a movement or to correct an individual. The instructor shall execute all movements correctly and smartly.

25. Demonstrations. Demonstrations shall be correct and be planned so that the squad can see the position or movement.

26. Checking. Constant checking and immediate correction of faults is essential.

27. Vocabulary. The instructor shall develop and use a vocabulary of short, concise words to impress on the squad that the movements must be performed smartly. For example, the words "crack", "drive", and "snap" indicate a high degree of smartness and precision.

28. Physical Contact. The instructor shall not touch members of the squad unless physically correcting movements or adjusting members' positions. Correction shall be performed in such a manner as to avoid perceptions of impropriety.

29. Punishment. Punishment shall not be meted out in response to incorrect drill movements. Instead, the instructor shall strive to determine and correct the causes of improper drill execution.

30. Rest Periods. In the early stages of drill training, short rest periods shall be given by standing the squad easy. During these rest periods, the squad may be questioned on subjects previously taught. Periods of drill at the halt shall be interspersed with drill on the march to keep the squad alert, exercise the muscles, and, as a result, produce a high standard of drill.

31. Formation for Instruction. The instructor shall select the most effective squad formation for the lesson being taught. A squad may be in a single rank, semi-circle or hollow square for elementary drill instruction.

32. Instructor Faults. Mistakes made by an instructor and noted by a superior shall be corrected as soon as possible away from the sight and hearing distance of the squad.

MECHANICAL TRAINING AIDS

33. Drum. A drum may be used to beat the time for drill at the halt and to beat the cadence for drill on the march.
34. Metronome. A metronome is an instrument that emits a sound and can be adjusted to indicate the timing for various movements.

PROCEDURES FOR CONDUCTING A DRILL LESSON

35. Preliminaries. Before commencing the lesson, the instructor shall:
- (1) order the squad into a suitable formation; e.g., hollow square
 - (2) review appropriate previous lessons
 - (3) state the movement to be taught and the reason for teaching
36. Lesson. The lesson shall be taught in the following stages:
- (1) Stage 1: Demonstration and Breakdown.
 - a. Demonstrate the complete movement, calling out the time.
 - b. Demonstrate the first part of the movement.
 - c. Explain how the first part of the movement is done.
 - d. Give the squad the opportunity to ask questions.
 - e. Practice the squad on the first movement.
 - f. Teach each subsequent movement following the sequence described above.
 - g. Give two complete and final demonstrations.
 - (2) Stage 2: Practice The Complete Movement.
 - a. Practice the complete movement with the instructor calling the time.
 - b. Practice the complete movement with the squad calling the time.
 - c. Practice the complete movement with the squad judging the time.

Note: On difficult movements, or movements with several stages, a further demonstration may be given prior to practising the complete movement.

37. Summary. The lesson shall be summarised as follows:
- (1) restate the movement taught and the reason for teaching
 - (2) state how well the squad performed on the movements
 - (3) state the next lesson

THIS PAGE INTENTIONALLY BLANK

CHAPTER 2

SQUAD DRILL AT THE HALT

FORMATION OF A SQUAD

1. Pathfinders shall be taught squad formations as soon as possible to maintain control and ensure uniformity throughout drill.

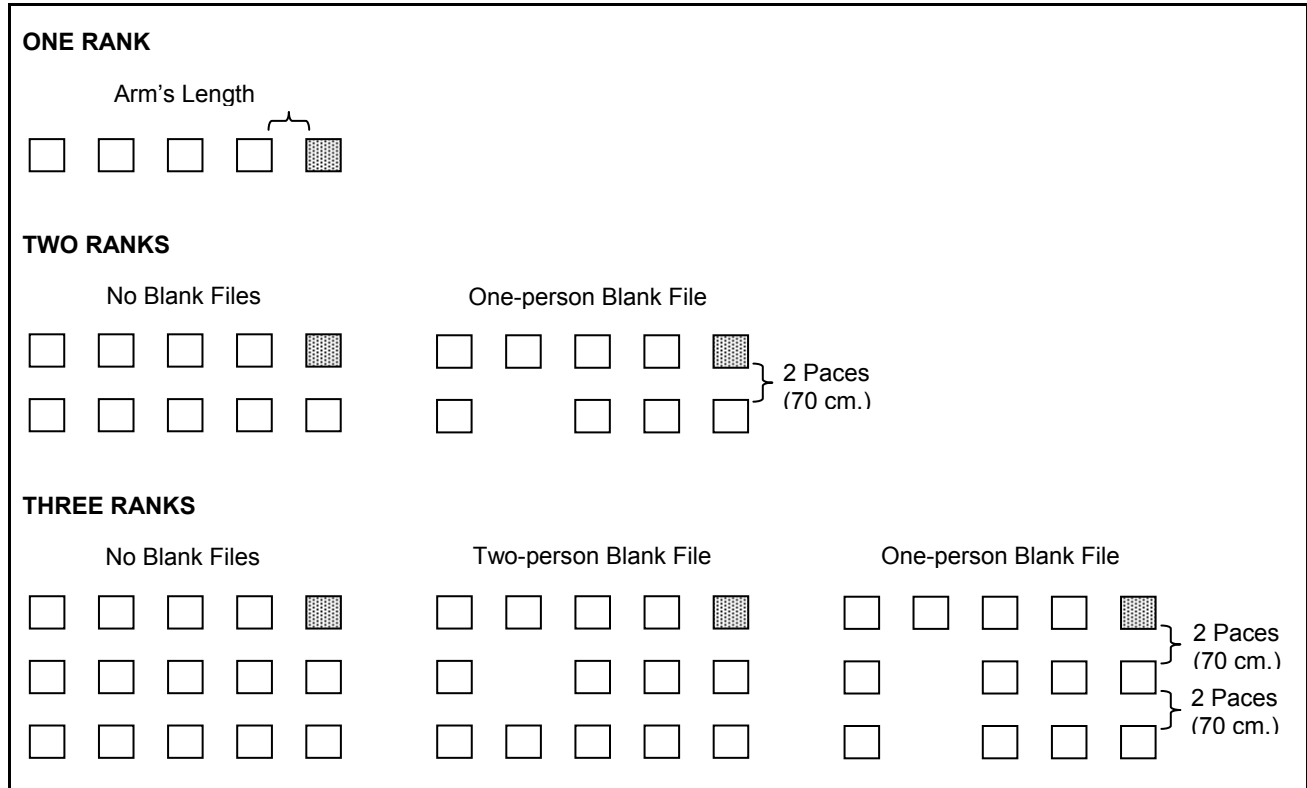

Figure 2-1: Squad Formations

2. The following shall be used in determining squad formations (Figure 2-1):
 - (1) five or fewer persons form up in one rank
 - (2) six to nine form up in two ranks
 - (3) ten or more form up in three ranks
3. On the command FORM UP IN ONE (TWO) (THREE) RANKS – MOVE, squad members shall:
 - (1) come smartly to attention
 - (2) step off with the left foot and march in quick time toward the instructor
 - (3) the first person approaching the instructor shall become the marker and halts either three paces to the instructor's front, or on a spot designated by the instructor; the remaining squad members shall:
 - a. in the case of one rank, halt at arm-length's intervals in line with, and to the left of, the marker
 - b. in the case of two ranks, the person closest to, and behind, the marker shall halt two paces behind the marker thus forming a rear rank

c. in the case of three ranks, the person closest to, and behind, the marker shall halt two paces behind the marker thus forming a centre rank with the person either immediately behind him or to his left halting two paces behind to form a rear rank

d. subsequent squad members shall fall in at arm's length intervals to the left of the markers in a front, centre, rear-rank, right-to-left manner

(4) upon taking up a position in the squad each member shall stand at ease

4. Squad members forming up on the left flank shall leave blank files in accordance with Figure 2-1.

5. At no time shall any squad member form up on the right of the marker.

ORDERING A SQUAD ON PARADE

6. Prior to being ordered on parade, squad members shall assemble at the edge of the parade ground in accordance with the instructions detailed above.

7. The instructor marches smartly and halts three paces in front of where he wishes the marker to fall in.

8. On the command MARKER, the marker shall:

(1) come smartly to attention

(2) observe the standard pause

(3) step off with the left foot and march in quick time

(4) halt three paces in front of, and facing, the instructor

(5) remain at attention

9. The instructor shall then turn right, march to where the centre of the squad will be once it has fallen in, halt, and turn left.

10. On the command SQUAD, FALL – IN, squad members shall:

(1) come smartly to attention

(2) observe the standard pause

(3) march in quick time onto the parade ground and halt to the left of the marker

(4) remain at attention

11. The instructor shall then proceed as required; e.g., ordering open order march, dressing the squad, etc.

DISMISSING A SQUAD

12. Dismissing signals the end of a parade, period of instruction, etc. The squad shall be in line and at attention when dismissed.

13. On the command DIS – MISS, squad members shall:

(1) turn right

(2) observe the standard pause

(3) salute, if wearing headdress and an officer is present

(4) observe the standard pause

(5) march off the parade ground individually and in quick time

14. The timing is counted as ONE, TWO – THREE, ONE, TWO –THREE, UP, TWO – THREE, DOWN, TWO – THREE, LEFT – RIGHT – LEFT. The officer shall return the salute on the eighth part of the timing.

15. If there is no officer present, or if there is an officer present while the squad is not wearing headdress, squad members shall not salute after turning right. The timing is counted as ONE, TWO – THREE, ONE, TWO –THREE, LEFT – RIGHT – LEFT.

POSITION OF ATTENTION

16. The position of attention is one of readiness and alertness and is the position adopted by juniors when addressing superiors.

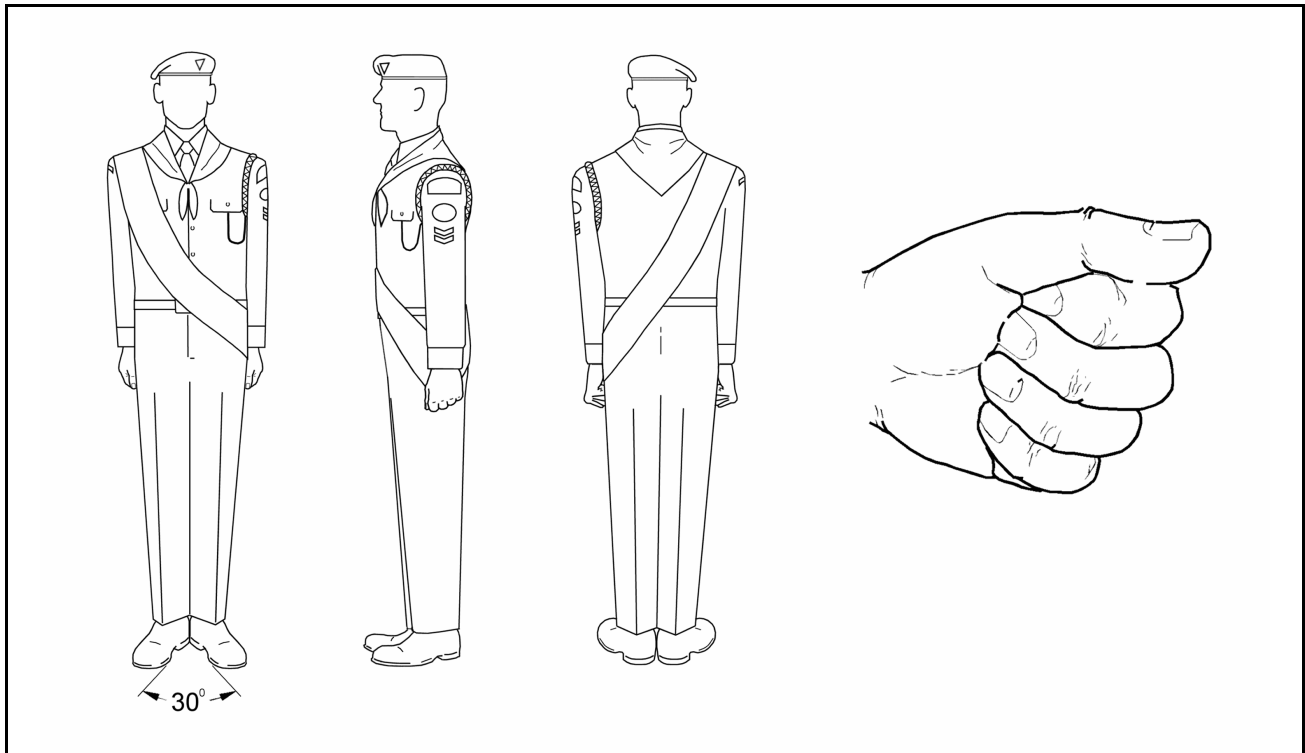

Figure 2-2: Position of Attention

17. The position of attention is as follows (Figure 2-2):

- (1) heels together and in line
- (2) feet turned outward so that the inside edges of the feet form an angle of 30 degrees
- (3) weight distributed evenly on both feet
- (4) fingers curled inward, forming a fist, with the thumb placed on the second joint of the forefinger
- (5) hands placed flat against the thighs with thumbs pointing downward in the centre of the leg
- (6) arms held as straight as possible with elbows and wrists touching the body
- (7) body upright and relaxed, shoulders level and square to the front, head level and erect, eyes looking straight to the front

18. No movement is permitted while at attention.

POSITION OF STAND AT EASE

19. The position of stand at ease is an intermediate position between attention and stand easy. Like the position of attention, it allows for no movement but can be maintained for longer periods without fatigue.

20. The position of stand at ease is as follows:

- (1) feet spread apart with the outside edges of the feet in line with the outermost part of the shoulders
- (2) toes in line and turned outward as for the position of attention
- (3) weight distributed evenly on both feet
- (4) hands held behind the back, right hand in the palm of the left, fingers straight and thumbs crossed right over left
- (5) arms kept as straight as possible by pushing the hands toward the ground

POSITION OF STAND EASY

21. The position of stand easy is ordered when it is desirable to permit personnel to relax. When standing easy, personnel are permitted to move but must not move their feet or talk.

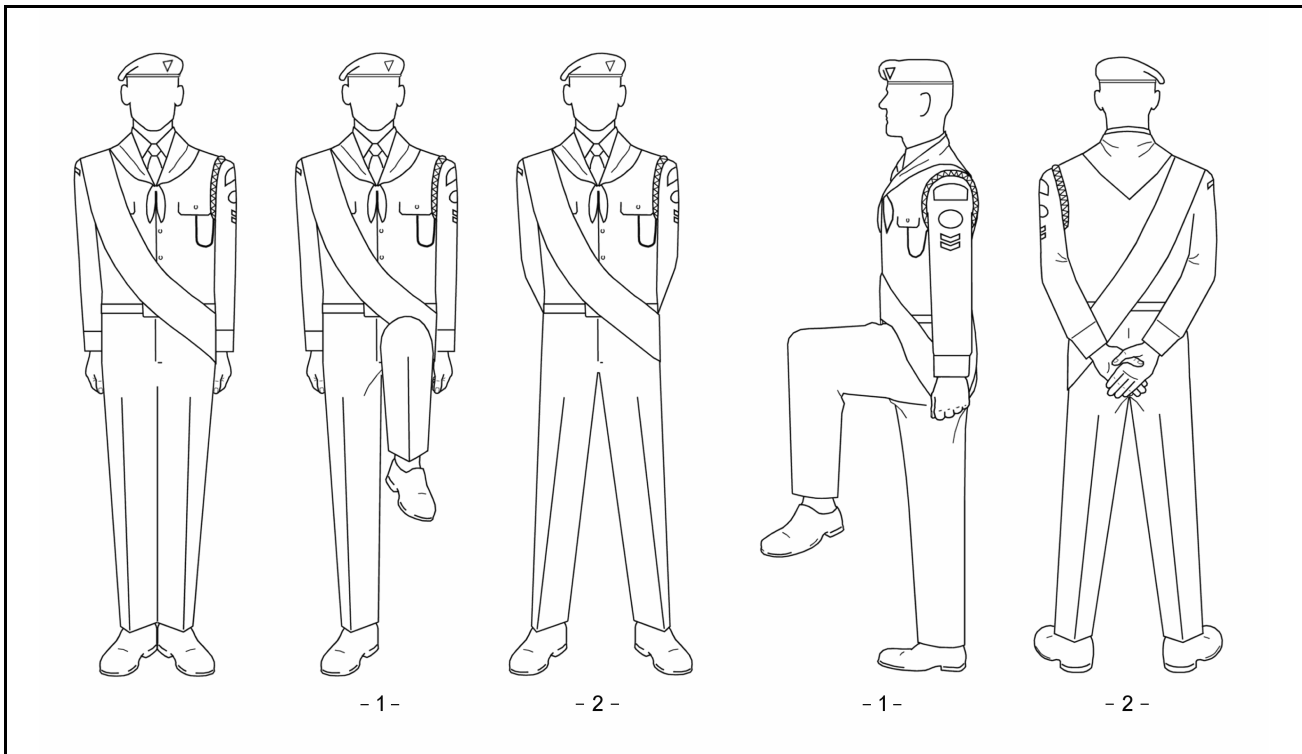

Figure 2-3: Position of Stand at Ease from Attention

STAND AT EASE FROM ATTENTION

22. On the command STAND AT EASE BY NUMBERS, SQUAD – ONE, squad members shall (Figure 2-3):

- (1) bend the left knee and raise the left leg so that the upper thigh and lower leg form a right angle with the upper thigh parallel to the ground and the toe of the left foot pointing downward
- (2) maintain balance on the right foot

23. On the command SQUAD – TWO, squad members shall:
- (1) carry the left foot to the left, then straighten the leg and place the left foot smartly on the ground, feet shoulder width apart as described for the position of standing at ease
 - (2) simultaneously, bring the arms behind the back with a quick motion and assume the position of stand at ease
24. On the command STAND AT – EASE, the two movements are combined and completed on the count of ONE.

STAND EASY FROM STAND AT EASE

25. The command Stand Easy is given only when the squad is standing at ease.

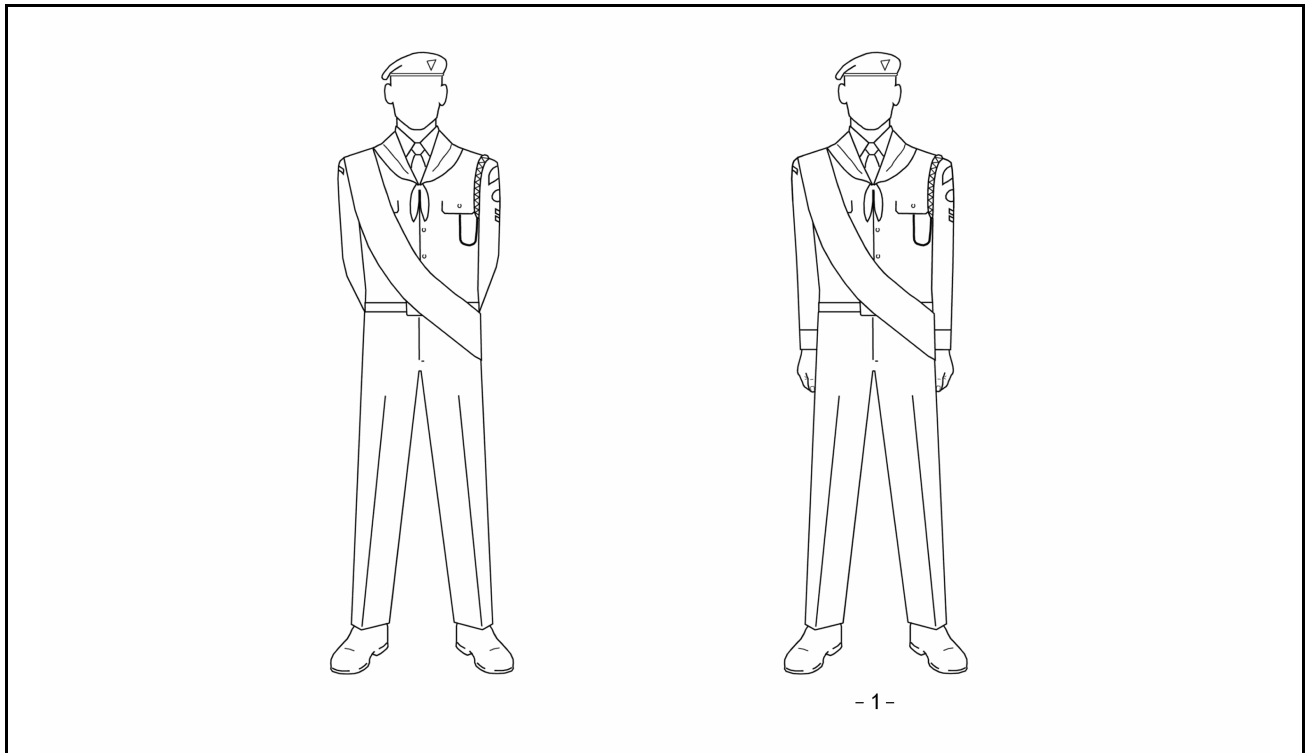

Figure 2-4: Position of Stand Easy from Stand at Ease

26. On the command STAND – EASY, squad members shall (Figure 2-4):
- (1) close the hands and bring the arms to the sides as for the position of attention
 - (2) observe the standard pause
 - (3) relax
27. The timing is counted as ONE, TWO – THREE.

STAND AT EASE FROM STAND EASY

28. Prior to ordering the squad to the position of stand at ease, the instructor may give the cautionary command STEADY UP to which squad members shall respond by placing their arms at their sides as for the position of stand easy. No timing is counted on this movement.

29. On the command SQUAD (PATHFINDERS, DRILL TEAM, etc.), squad members shall move immediately to the position of stand at ease. The timing is counted as ONE.

ATTENTION FROM STAND AT EASE

30. On the command ATTENTION BY NUMBERS, SQUAD – ONE, squad members shall:

- (1) bend the left knee and raise the left leg so that the upper thigh and lower leg form a right angle with the upper thigh parallel to the ground and the toe of the left foot pointing downward
- (2) maintain balance on the right leg

31. On the command SQUAD – TWO, squad members shall:

- (1) straighten the left leg, placing the foot smartly on the ground, toe touching first followed by the heel, and with feet positioned as described for the position of attention
- (2) simultaneously, bring the hands and arms to the sides with a quick motion and assume the position of attention

32. On the command ATTEN – TION, the two movements are combined and completed on the count of ONE.

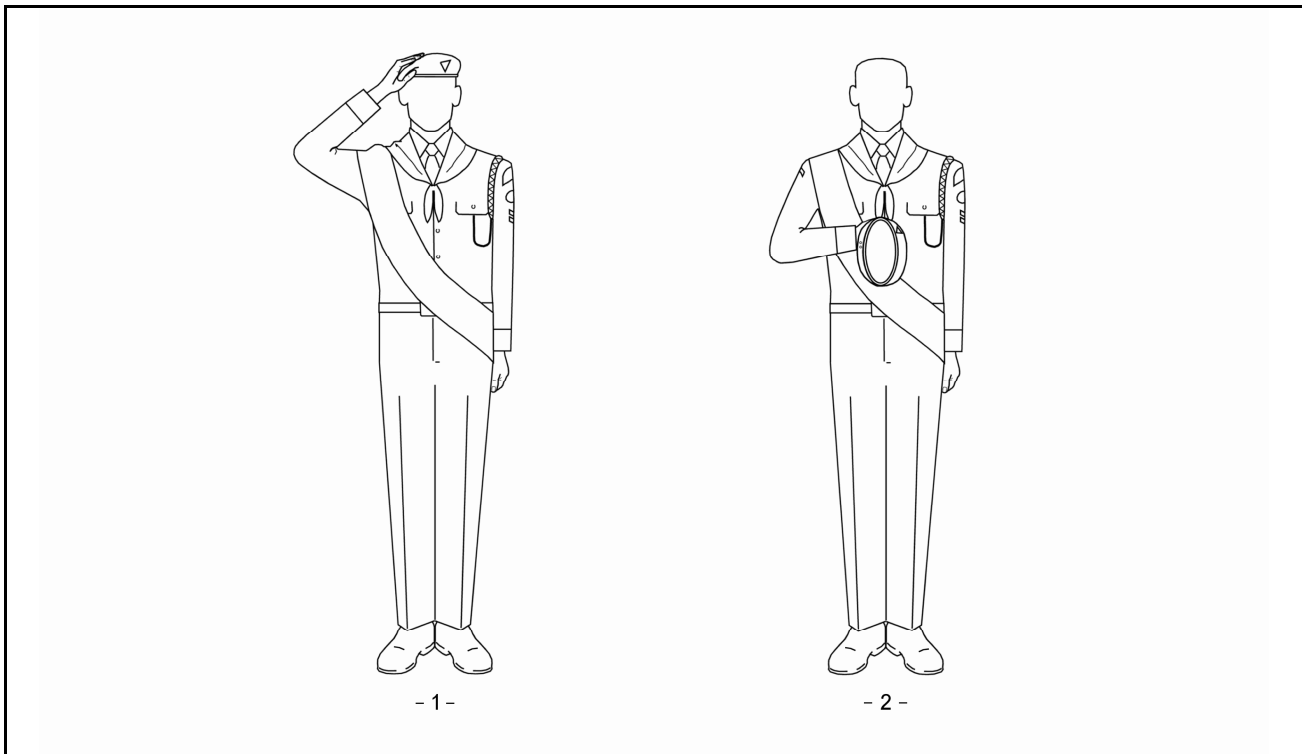

Figure 2-5: Position of Remove Headdress

REMOVE HEADDRESS

33. The order to remove headdress is customarily given before prayers or when it is desirable to honour a dignitary by giving three cheers.

34. When ordered, all ranks shall remove headdress with the exception of female members of the Canadian Pathfinder organisation or musicians parading with instruments.

35. On the command REMOVE HEADDRESS BY NUMBERS, SQUAD – ONE, squad members shall (Figure 2-5):

- (1) bring the right hand to the front of the headdress by the shortest route, grasping the headdress between the thumb and fingers of the right hand
- (2) keep the upper arm parallel to the ground

36. On the command SQUAD – TWO, squad members shall:

- (1) bring the right hand straight down to the centre of the chest, hand flat against the chest and thumb uppermost
- (2) keep the elbow bent and forearm parallel to the ground

37. On the command REMOVE – HEADDRESS, the two movements are combined with a standard pause between each movement. The timing is counted as ONE, TWO – THREE, ONE.

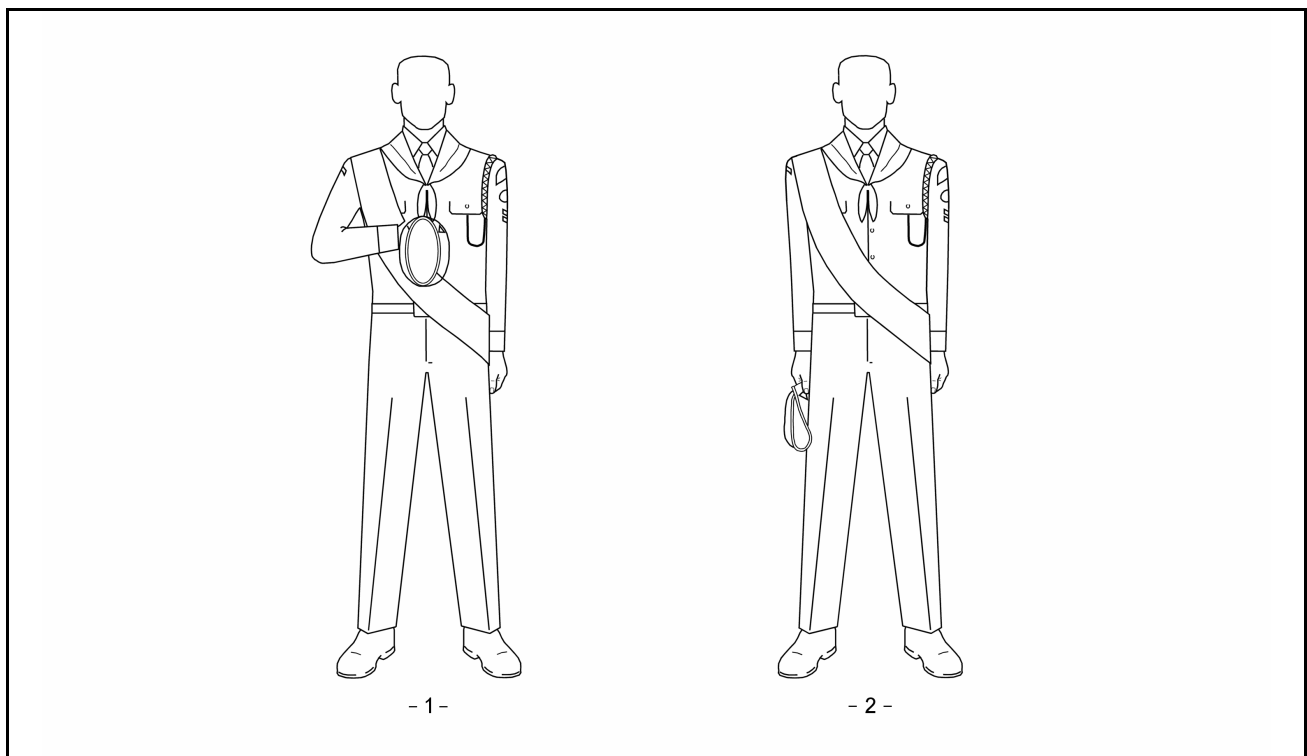

Figure 2-6: Positions of Stand at Ease and Stand Easy with Headdress Removed

STAND AT EASE WITH HEADDRESS REMOVED

38. On the command STAND AT – EASE (Figure 2-6):

- (1) squad members who are not required to remove headdress shall stand at ease
- (2) squad members who have removed headdress shall assume the position of stand at ease by moving only the left leg

39. The timing is counted as ONE.

STAND EASY WITH HEADDRESS REMOVED

40. On the command STAND – EASY, squad members shall (Figure 2-6):
- (1) bring the arms to the sides as for the position of standing easy, with the headdress grasped firmly in the right hand if headdress has been removed
 - (2) observe the standard pause
 - (3) relax
41. The timing is counted as ONE, TWO – THREE.

REPLACE HEADDRESS

42. Squad members shall be ordered to the position of attention prior to replacing headdress. On the cautionary command SQUAD (PATHFINDERS, DRILL TEAM, etc.), squad members shall bring the right hand to the centre of the chest and assume the position of stand at ease with headdress removed. On the command ATTEN – TION, squad members shall assume the position of attention with headdress removed.
43. On the command REPLACE HEADDRESS BY NUMBERS, SQUAD – ONE, squad members shall replace and adjust the headdress with two hands, right hand to the right-front of the head and left hand to the left-rear.
44. On the command SQUAD – TWO, squad members shall bring both arms sharply to the sides and assume the position of attention.
45. On the command REPLACE – HEADDRESS, the two movements are combined with a standard pause between each movement. The timing is counted as ONE, TWO – THREE, ONE.
46. After headdress has been replaced, it may be desirable to stand squad members easy to allow them extra time to adjust their headdress.

SALUTING AT THE HALT

47. The salute is given with the right hand. Pathfinders not wearing headdress, unable to render a hand salute due to physical incapacitation, or who are carrying articles that require the use of both hands may salute by turning the head and eyes right or left or by standing at attention.
48. On the command TO THE FRONT SALUTE BY NUMBERS, SQUAD – ONE, squad members shall bend the elbow and bring the right hand up to the side of the head by the shortest route, opening the hand as it passes the shoulder, so that (Figure 2-7):
- (1) the thumb and fingers are fully extended and touching each other
 - (2) the tip of the second finger touches the either the outer corner of the right eyebrow, or, if glasses are worn, the outside edge of the glasses
 - (3) the palm of the hand faces down
 - (4) the hand, wrist, and forearm form a straight line 45 degrees to the upper arm
 - (5) the upper arm is parallel to the ground
 - (6) the elbow is in line with the shoulders
49. On the command SQUAD – TWO, the hand is brought to the position of attention by the shortest route without slapping the thigh. The hand is closed as the forearm is lowered below shoulder level.

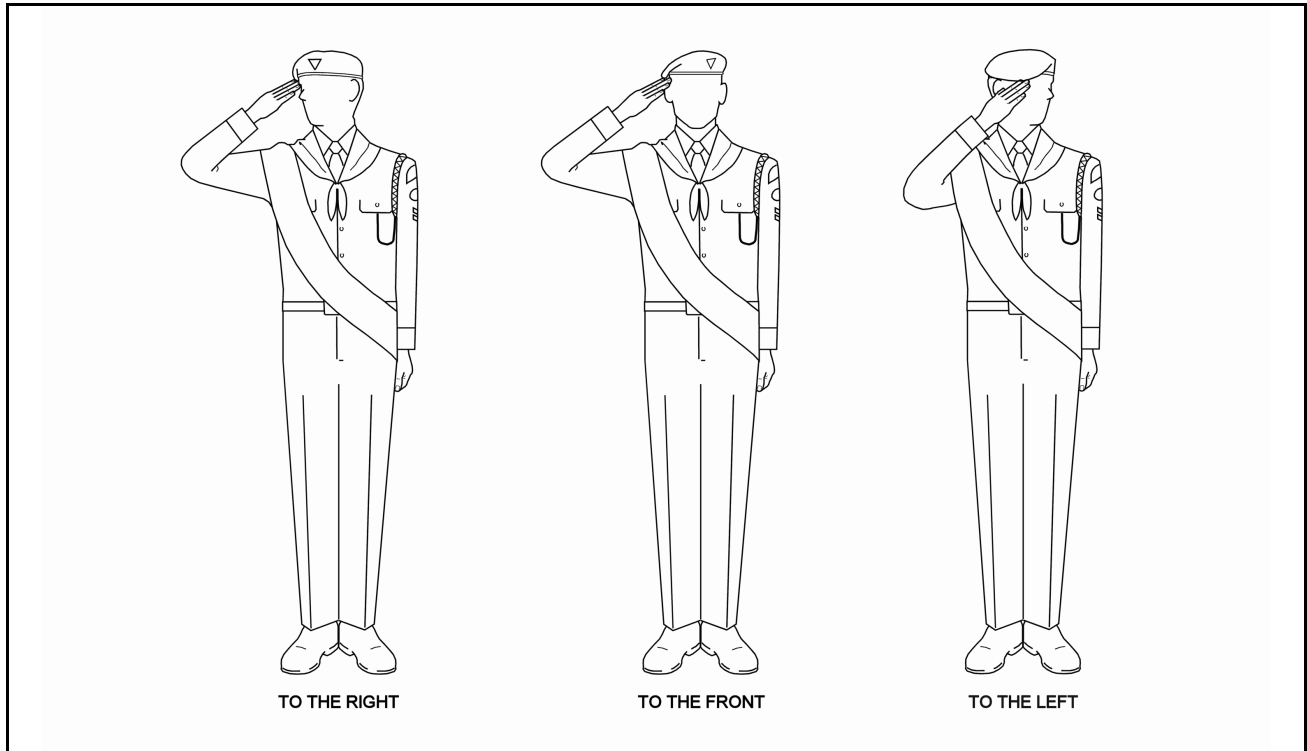

Figure 2-7: Saluting at the Halt

50. On the command **TO THE FRONT – SALUTE**, the two movements are combined with a standard pause between each movement. The timing is counted as **UP, TWO – THREE, DOWN**.

51. On the command **TO THE RIGHT (LEFT) SALUTE BY NUMBERS, SQUAD – ONE**, saluting is executed as for saluting to the front except that:

- (1) the head and eyes are turned smartly to the right (left) as far as possible without straining
- (2) the elbow is brought forward to maintain the correct position when saluting to the left

52. On the command **SQUAD – TWO**:

- (1) the hand is brought smartly to the position of attention
- (2) the head and eyes are simultaneously turned sharply to the front

TURNING AND INCLINING

53. Turns and inclines are made to change direction: right and left inclines change direction by 45 degrees, right and left turns by 90 degrees, and about turns by 180 degrees.

54. On the command **RIGHT TURN BY NUMBERS, SQUAD – ONE**, squad members shall (Figure 2-8):

- (1) turn 90 degrees to the right by pivoting on the right heel and left toe while raising the right toe and left heel slightly
- (2) brace both knees during the turn, keeping the arms straight at the sides and the body erect

55. On completion of the movement the weight of the body is on the right foot, right foot flat on the ground, with the left leg braced and the left heel raised.

56. On the command SQUAD – TWO, squad members shall:

- (1) bend the left knee and raise the left leg so that the upper thigh and lower leg form a right angle with the upper thigh parallel to the ground and the toe of the left foot pointing downward
- (2) straighten the left leg, placing the foot smartly on the ground beside the right, and assume the position of attention

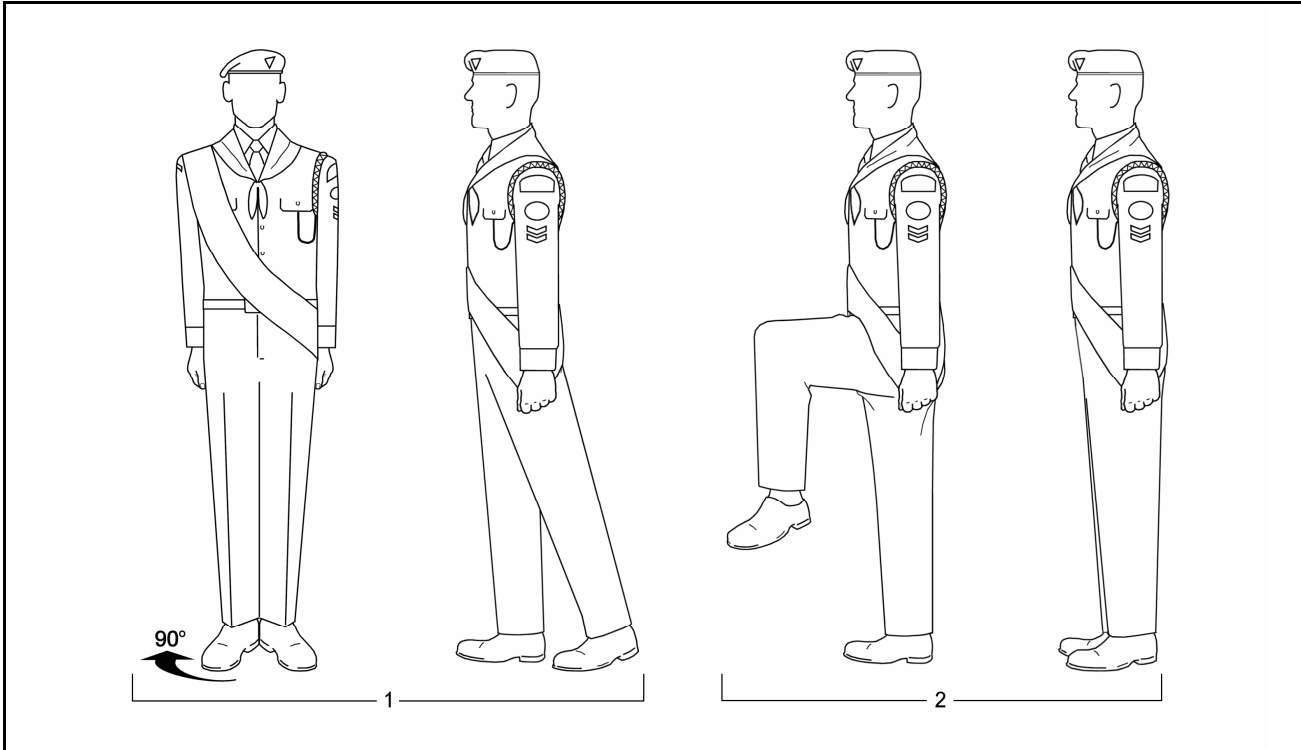

Figure 2-8: Right Turn

57. On the command RIGHT – TURN, the two movements are combined with a standard pause between each movement. The timing is counted as ONE, TWO – THREE, ONE.

58. On the command RIGHT IN – CLINE, the drill is executed as for a right turn except the pivot is made through 45 degrees.

59. On the command LEFT – TURN, the drill is executed as for a right turn except the pivot is made on the left heel and right toe.

60. On the command LEFT IN – CLINE, the drill is executed as for a left turn except the pivot is made through 45 degrees.

61. On the command ABOUT – TURN, the drill is executed as for a right turn except the pivot is made through 180 degrees. Balance is maintained by bracing the legs and locking the thighs.

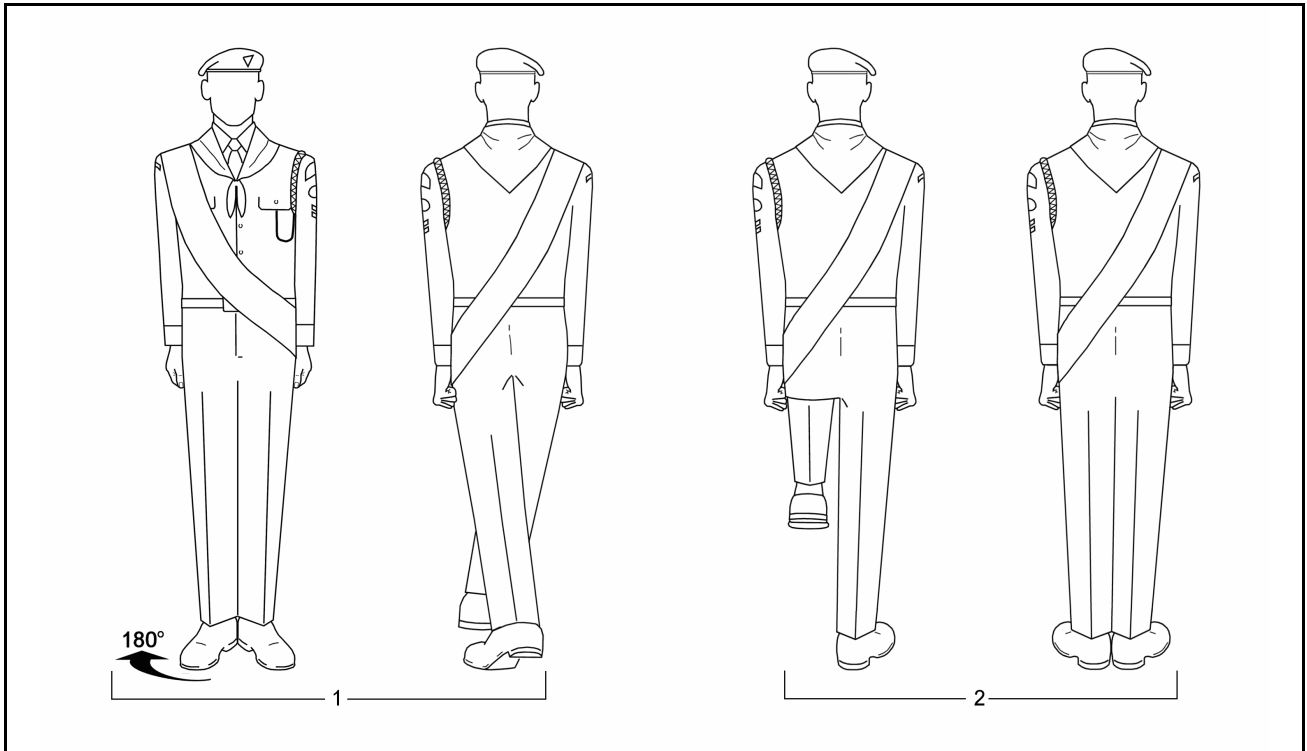

Figure 2-9: About Turn

CLOSING TO THE RIGHT AND LEFT

62. Closing to the right or left shall only be ordered for distances of eight or fewer paces. When the distance exceeds eight paces, the squad shall be turned right or left and marched the required distance.

63. On the command ONE PACE RIGHT CLOSE MARCH BY NUMBERS, SQUAD – ONE, squad members shall:

- (1) bend the right knee so that the upper thigh is parallel to the ground, carry the right foot to the right, and place the foot smartly on the ground shoulder width apart as for the position of stand at ease
- (2) balance the weight of the body evenly on both feet
- (3) keep the arms straight at the sides

64. On the command SQUAD – TWO, squad members shall:

- (1) shift the weight of the body to the right foot
- (2) bend the left knee and raise the left leg so that the upper thigh and lower leg form a right angle with the upper thigh and the toe of the left foot pointing downward
- (3) straighten the leg, placing the left foot smartly on the ground beside the right, and assume the position of attention.

65. On the command ONE PACE LEFT CLOSE MARCH BY NUMBERS, SQUAD – ONE, the drill is executed as for closing to the right except the direction and details of moving the feet are reversed.

66. On the command ONE PACE RIGHT (LEFT) CLOSE – MARCH, the two movements are combined, observing the timing noted below:

- (1) for one pace the timing is counted as ONE – TWO

- (2) for two paces the timing is counted as ONE – TWO, PAUSE, TWO – TWO
- (3) for three paces the timing is counted as ONE – TWO, PAUSE, TWO – TWO, PAUSE, THREE – TWO
- (4) etc.

PACES FORWARD AND TO THE REAR

67. Paces forward or to the rear shall only be ordered for distances of three or fewer paces. When the distance exceeds three paces, the squad shall be marched the required distance. If the distance exceeds three paces and the squad is required to move to the rear, the squad shall be turned about before moving.

68. When taking paces forward and to the rear:

- (1) the cadence shall be in quick time
- (2) the length of each step shall be one half pace (35 cm.)

69. On the command ONE PACE FORWARD MARCH BY NUMBERS, SQUAD – ONE, squad members shall:

- (1) shoot the left foot forward one half pace, placing the weight on the left foot with the right heel raised
- (2) keep the arms straight at the sides

70. On the command SQUAD – TWO, squad members shall:

- (1) bend the right knee and raise the right leg so that the upper thigh and lower leg form a right angle with the upper thigh parallel to the ground and the toe of the right foot pointing downward
- (2) straighten the right leg, placing the foot smartly on the ground beside the left, and assume the position of attention

71. On the command ONE PACE FORWARD – MARCH, the two movements are combined.

72. On the command ONE PACE BACKWARD MARCH BY NUMBERS, SQUAD – ONE, squad members shall;

- (1) shoot the left foot backward one half pace, placing the weight on the right foot with the left heel raised
- (2) keep the arms straight at the sides

73. On the command SQUAD – TWO, squad members shall:

- (1) shift the weight to the left foot
- (2) bend the right knee and raise the right leg so that the upper thigh and lower leg form a right angle with the upper thigh parallel to the ground and the toe of the right foot pointing downward
- (3) straighten right the leg, placing the foot smartly on the ground beside the left, and assume the position of attention

74. On the command ONE PACE BACKWARD – MARCH, the two movements are combined.

75. On the command TWO PACES FORWARD (BACKWARD) – MARCH, the movements shall be carried out as described above except that on the final movement the left foot shall be brought down beside the right to assume the position of attention.

76. The timings for paces forward and to the rear are counted as follows:

- (1) for one pace, ONE – TWO
- (2) for two paces, ONE – ONE – TWO
- (3) for three paces, ONE – ONE – ONE – TWO

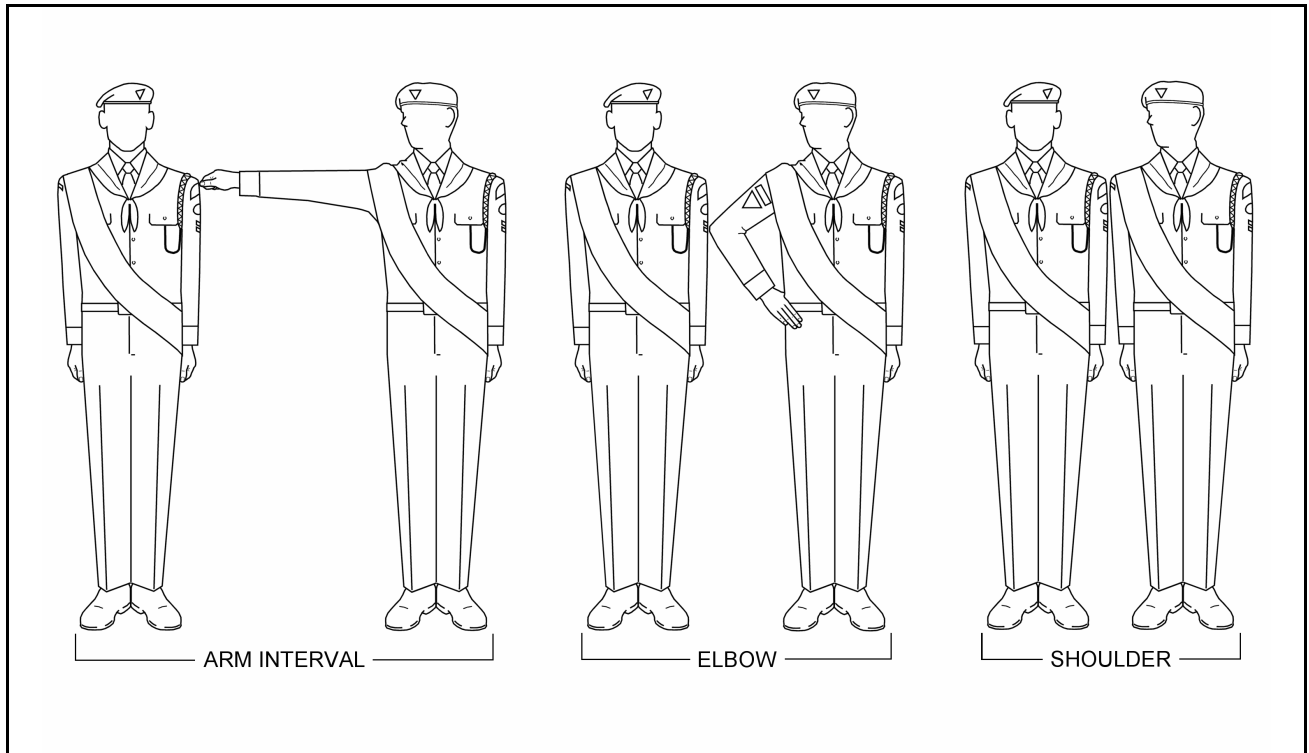

Figure 2-10: Dressing a Squad

DRESSING A SQUAD

77. On the command RIGHT DRESS BY NUMBERS, SQUAD – ONE (Figure 2-10):

- (1) the marker stands fast
- (2) the remainder shoot the left foot forward a half (35 cm.) pace, placing the weight on the left foot with the right heel raised

78. On the command SQUAD – TWO, all except the marker:

- (1) bend the right knee and raise the right leg so that the upper thigh and lower leg form a right angle with the upper thigh parallel to the ground and the toe of the right foot pointing downward
- (2) straighten right the leg, placing the foot smartly on the ground beside the left, and assume the position of attention

79. On the command SQUAD – THREE:

- (1) the right file stands fast
- (2) the remainder turn their heads and eyes sharply to the right as far as possible, without straining

- (3) simultaneously, the front rank quickly raise their right arms behind the shoulder of the person to their right, arm fully extended and parallel to the ground, with the hand closed as for the position of attention

80. On the command SQUAD – FOUR:

- (1) the marker stands fast
- (2) the remainder take up correct alignment and distance by taking short, sharp paces on the heels starting off with the left foot

81. When correctly aligned, each squad member, except the right file, should just be able to see the lower part of the face of the person two files to the right while those in the centre and rear ranks should be positioned behind the front rank. Intervals are correct when the right hand is just touching the shoulder of the person on the right. Correct distance between ranks is achieved by the centre and rear markers taking up position in accordance with Figure 2-11.

82. On the command RIGHT – DRESS, the four movements are combined with a standard pause between each movement. The timing is counted as ONE – TWO, TWO – THREE, ARMS, TWO – THREE, MOVE.

83. On the command EYES – FRONT, squad members shall:

- (1) snap the head and eyes to the front
- (2) simultaneously, the front rank bring their arms sharply to the sides, without slapping the thighs, and assume the position of attention

84. On the command ELBOW DRESSING – RIGHT DRESS, the drill is executed as for right dress except:

- (1) the right hand is placed on the hip, fingers closed and pointing downward with the thumb behind the back
- (2) the point of the elbow is parallel to the front of the body and touches the left arm of the person to the right

85. On the command SHOULDER DRESSING – RIGHT DRESS, the drill is executed as for right dress except that the arms are not raised and dressing is shoulder to shoulder.

OPEN ORDER MARCH

86. The open order is used to allow inspecting parties room to pass freely through a squad or to create space between ranks for activities that require a great deal of physical movement (callisthenics, etc.)

87. On the command OPEN ORDER – MARCH, the drill and timing are executed as for three paces forward and to the rear. When formed in three ranks the centre rank stands fast while the front rank steps forward and the rear rank steps backward. If formed in two ranks the front rank stands fast while the rear rank steps backward (Figure 2-11).

88. The squad shall be dressed after executing an open order.

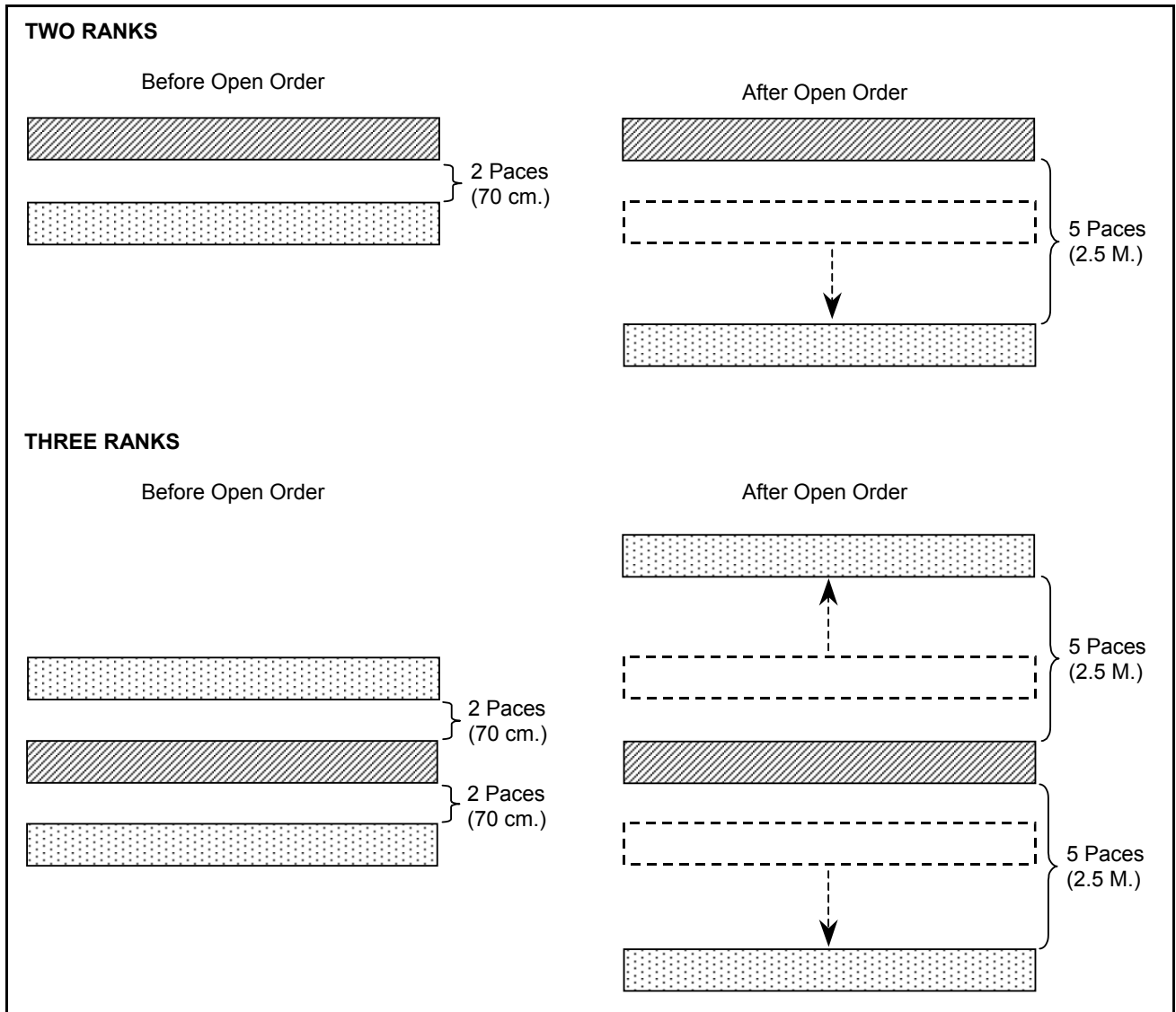

Figure 2-11: Open Order March

CLOSE ORDER MARCH

89. On the command CLOSE ORDER – MARCH, the squad shall reverse the movements described for open order march.

90. The squad shall be dressed after executing a close order.

CARRYING OF OBJECTS

91. Objects are held in the left hand with both arms kept straight and at the sides as for the position if attention. If an object is carried while marching only the right arm is swung.

PROVING

92. Proving is used by squad members to identify themselves, either by name or by their location in the squad, or when squad members wish to make requests and ask or answer questions.

93. On the command NUMBER ONE (TWO, THREE, etc.) FRONT (CENTRE or REAR) RANK, or PATHFINDER (SMITH, JONES, etc.) – PROVE, the persons so ordered shall:

- (1) come smartly to attention, if not already standing at attention
- (2) raise the right forearm parallel to the ground, thumb uppermost, keeping the elbow bent and close to the body and the hand closed as for the position of attention

94. On the command ATTEN – TION, the members who proved shall drop their arms smartly to the side and assume the position of attention.

95. When making requests or asking questions, squad members shall come smartly to attention and prove, shouting “SIR” or “MA’AM” if the squad commander is an officer, and await acknowledgement.

96. After proving, squad members shall then proceed as necessary; e.g., assuming the same position as the squad, falling out, etc.

NUMBERING

97. Numbering is used to designate individuals in the squad and to determine the number of persons on parade.

98. On the command SQUAD – NUMBER, the front rank only shall count off loudly from right to left in ones, the marker starting with ONE, the next person TWO, and so on. The head and eyes remain fixed to the front when counting and there is no pause between numbers.

99. Personnel in the centre and rear ranks take the number of the front rank individual in their respective files.

100. If an error in numbering occurs, the command AS YOU WERE, SQUAD – NUMBER, shall be ordered and the squad shall renumber from the beginning.

CALLING THE ROLL

101. On the command ATTEN – TION, ANSWER TO YOUR NAME, STAND AT – EASE, each squad member shall come smartly to attention as his name is called and answer in one of the following ways:

- (1) “SIR” or “MA’AM” if the person calling or supervising the roll is an officer
- (2) “PRESENT” if the person calling or supervising the roll is below officer rank

102. Each person shall stand at ease after answering to his name.

FALLING OUT OF RANKS

103. Falling out is used to call individuals out of the squad by name or location in the squad, or by personnel who have requested and received permission to exit the squad.

104. On the command NUMBER ONE (TWO, THREE, etc.) FRONT (CENTRE or REAR) RANK, or PATHFINDER (SMITH, JONES, etc.), FALL – OUT, the persons so ordered shall (Figure 2-12):

- (1) come smartly to attention
- (2) observe the standard pause
- (3) wheel right and march, in quick time, to the right flank
- (4) continue to march in the required direction upon reaching the right flank

105. If the squad is at the close order, the arms shall be held at the sides and not swung until clear of the right flank.

106. Personnel who have asked permission to fall out by proving, and have received permission, shall fall out as described above without being given the command to fall out.

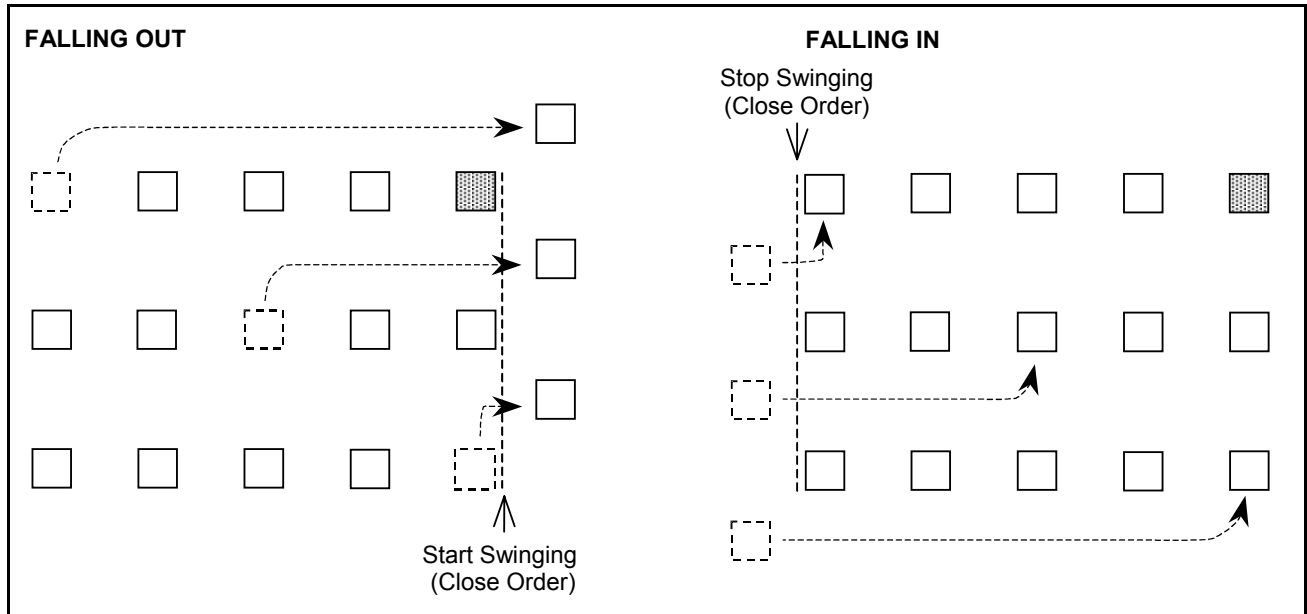

Figure 2-12: Falling in and Out of Ranks

FALLING IN

107. The procedure for falling in is as follows:

- (1) a squad member shall march to, and halt in front of, the instructor and request permission to fall in
- (2) if given permission to fall in, turn toward the left flank of the squad by executing a left or right turn as appropriate
- (3) march to the left flank
- (4) return to his former position by marching behind his rank, wheeling into position, and halting
- (5) take up proper dressing and assume the same position as the squad

108. If the squad is at the close order, the arms shall be brought sharply to the sides upon reaching the left flank.

109. Squad members joining the squad for the first time shall follow the procedures for falling in as described above except that they shall take up a position:

- (1) in the blank file, if there is only one blank file
- (2) in the rearmost blank file, if there are two blank files
- (3) on the far left flank of the front rank if there are no blank files

110. In the case of a squad member falling in on the left flank of the front rank, the instructor may adjust the dressing of the squad by ordering the squad members in the centre and/or rear ranks of the far left file to cover over behind the person who has just fallen in, or by ordering a right dress.

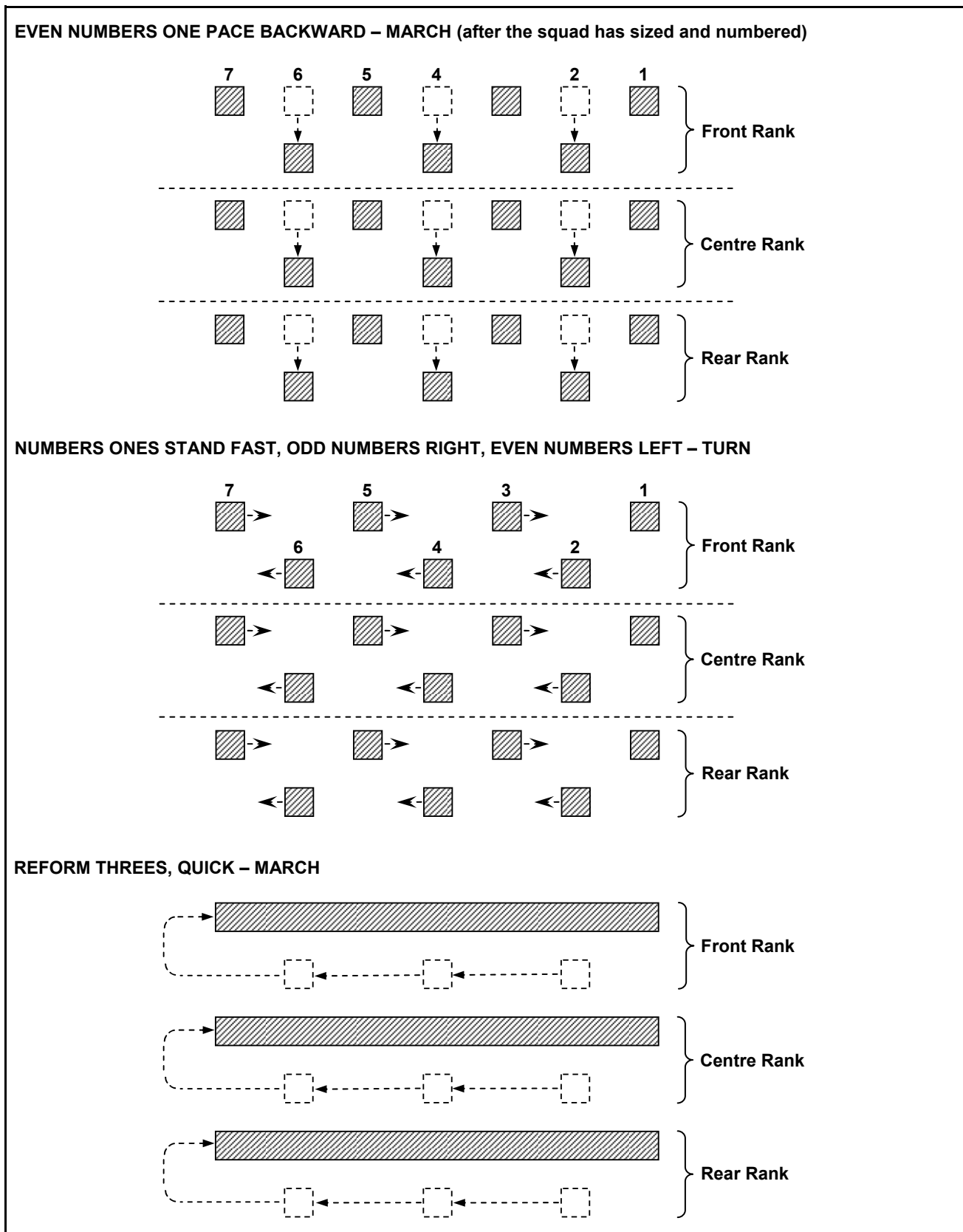

Figure 2-13: Sizing and Reforming in Three Ranks

SIZING AND REFORMING IN THREE RANKS

111. A squad is sized for aesthetic balance and to give the best impression to spectators. However, practical considerations should take precedence over sizing as it may be necessary to designate the position of squad members according to their individual proficiency at drill; e.g., appointing a shorter member as marker because of his ability to maintain a consistent pace and cadence when marching.

112. On the command **TALLEST ON THE RIGHT, SHORTEST ON THE LEFT, IN THREE RANKS – SIZE**, squad members shall (Figure 2-13):

- (1) turn right
- (2) observe the standard pause
- (3) arrange themselves within their respective ranks tallest to shortest, from right to left, at arm's length intervals and covering off front to rear

113. The timing is counted as **ONE, TWO – THREE, ONE, TWO – THREE**.

114. The instructor then orders **OPEN ORDER – MARCH** followed by **SQUAD – NUMBER**. The timing for the open order is counted as **ONE – ONE – ONE – TWO**.

115. On the command **EVEN NUMBERS ONE PACE BACKWARD – MARCH**, the even numbers shall take a half (35 cm.) pace backward. The timing is counted as **ONE – TWO**.

116. On the command **NUMBER ONES STAND FAST, ODD NUMBERS RIGHT, EVEN NUMBERS LEFT – TURN**, everyone except the right file shall turn right. The timing is counted as **ONE, TWO – THREE, ONE**.

117. On the command **REFORM THREES, QUICK – MARCH**:

- (1) the right file stands fast
- (2) the odd numbers march toward the number one person of their respective ranks
- (3) the even numbers follow the odd numbers, wheeling at the left flank of the formation
- (4) each person shall halt upon arriving at his new position, at arm's length intervals from the person to his right, observe the standard pause, then turn left and remain at attention
- (5) no timing is counted on this movement.

118. The squad shall be dressed after sizing and reforming in three ranks.

SIZING AND REFORMING IN TWO RANKS

119. Sizing in two ranks is performed as for sizing in three ranks except that:

- (1) the initial command shall be **TALLEST ON THE RIGHT, SHORTEST ON THE LEFT, IN TWO RANKS – SIZE**
- (2) only the rear rank moves during the open order
- (3) the command to reform shall be **REFORM TWOS, QUICK – MARCH**

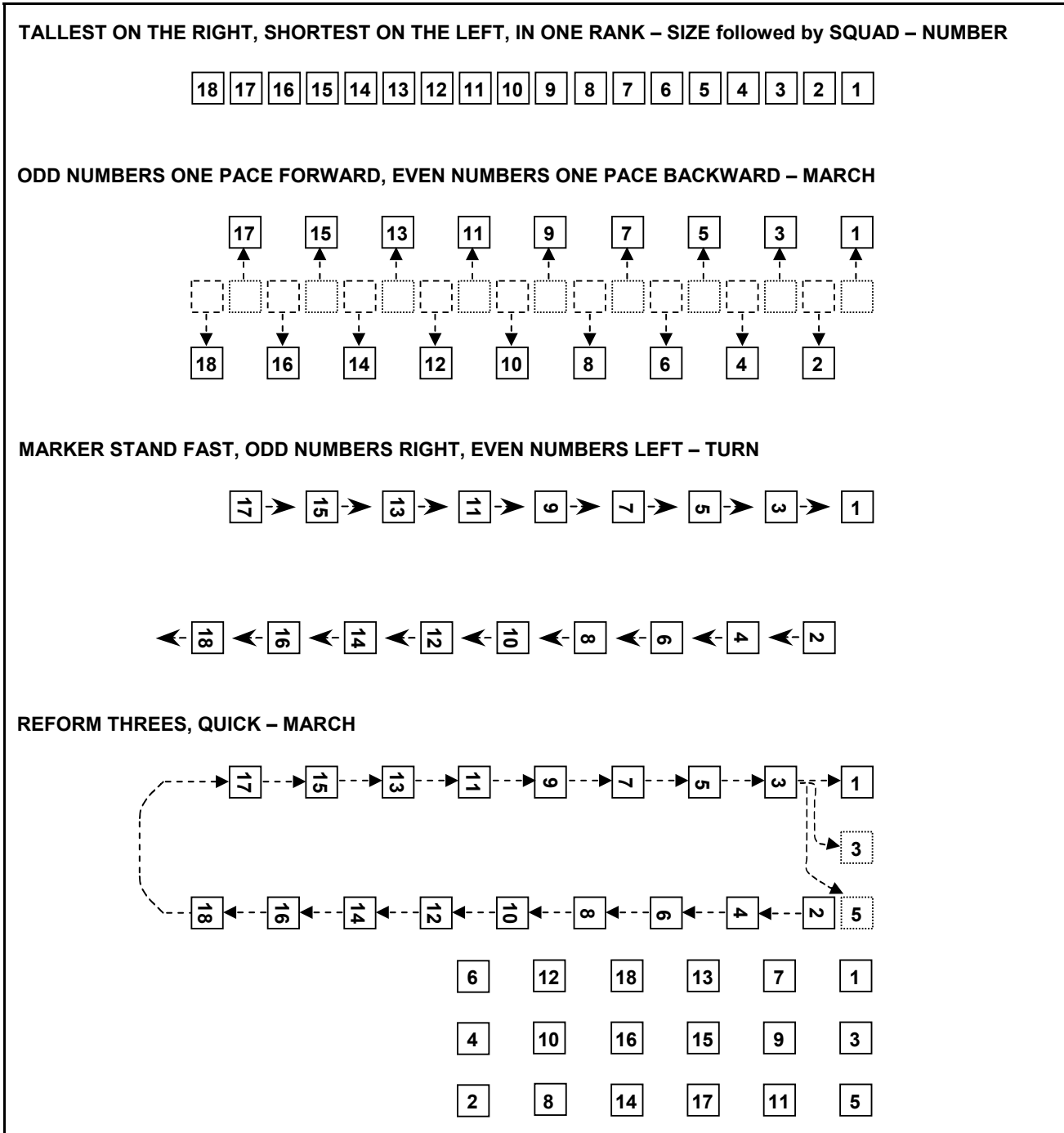

Figure 2-14: Sizing in One Rank and Reforming in Threes

SIZING IN ONE RANK AND REFORMING IN THREE RANKS (OPTIONAL)

120. On the command **TALLEST ON THE RIGHT, SHORTEST ON THE LEFT, IN ONE RANK – SIZE**, squad members shall:

- (1) turn right
- (2) observe the standard pause
- (3) arrange themselves in one rank tallest to shortest, from right to left, at shoulder dressing

121. The timing is counted as ONE, TWO – THREE, ONE, TWO – THREE.

122. On the command SQUAD – NUMBER, the squad shall act as ordered.

123. On the command ODD NUMBERS ONE PACE FORWARD, EVEN NUMBERS ONE PACE BACKWARD – MARCH, the squad shall take one pace forward or backward, as ordered. The timing is counted as ONE – TWO.

124. On the command MARKER STAND FAST, ODD NUMBERS RIGHT, EVEN NUMBERS LEFT – TURN, everyone except the marker shall turn as ordered. The timing is counted as ONE, TWO – THREE, ONE.

125. On the command REFORM THREES, QUICK – MARCH:

- (1) the marker stands fast
- (2) the number three person marches one pace toward the marker then wheels right taking up a position two half (35 cm.) paces behind the marker and facing right, becoming the centre rank marker
- (3) the number five person marches forward, wheels where the number three person wheeled, and takes up a position two half (35 cm.) paces behind the number three person and facing right, becoming the rear rank marker
- (4) squad members continue to take up positions in a centre-rank, rear-rank, front-rank manner with the even numbers wheeling at the flank of the formation to follow the odd numbers
- (5) each person shall halt upon arriving at his new position, at arm's length intervals from the person to his right, observe the standard pause, then turn left and remain at attention
- (6) no timing is counted on this movement

126. The squad shall be dressed after sizing in one rank and reforming in three ranks.

FORMING TWO RANKS FROM THREE RANKS (OPTIONAL)

127. The squad shall be in close order, dressed at arm's length intervals, and numbered prior to forming two ranks from three.

128. On the command FORM TWO RANKS BY NUMBERS, SQUAD – ONE, the centre rank closes one pace left. The timing is counted as ONE – TWO.

129. On the command SQUAD – TWO:

- (1) odd numbers take two half (35 cm.) paces forward into the front rank, stepping off with the left foot, then halt and remain at attention
- (2) even numbers take two half (35 cm.) paces backward into the rear rank, stepping off with the left foot, then halt and remain at attention

130. The timing is counted as ONE – ONE – TWO.

131. On the command FORM TWO – RANKS, the two movements are combined with a standard pause between each movement. The timing is counted as ONE – TWO, TWO – THREE, ONE – ONE – TWO.

132. When there are one or two blank files and an odd number of files, the person on the left flank shall take two paces backward instead of forward.

133. When there is one blank file and an even number of files, the person on the left flank shall take two paces forward instead of backward.

134. The squad shall be dressed after forming two ranks.

REFORMING THREE RANKS FROM TWO RANKS (OPTIONAL)

135. The squad shall be in close order and dressed at arm's length intervals prior to reforming three ranks.
136. On the command REFORM THREE RANKS BY NUMBERS, SQUAD – ONE:
 - (1) the original odd numbers of the centre rank take two half (35 cm.) paces backward, stepping off with the left foot, then halt and remain at attention
 - (2) the original even numbers of the centre rank take two half (35 cm.) paces forward, stepping off with the left foot, then halt and remain at attention
137. The timing is counted as ONE – ONE – TWO.
138. On the command SQUAD – TWO, the centre rank closes one pace right. The timing is counted as ONE – TWO.
139. On the command REFORM THREE – RANKS, the two movements are combined with a standard pause between each movement. The timing is counted as ONE – ONE – TWO, TWO – THREE, ONE – TWO.
140. The squad shall be dressed after reforming three ranks.

CHAPTER 3

SQUAD DRILL ON THE MARCH

FUNDAMENTALS

1. The Canadian Pathfinder organisation marches in quick, slow and double time.
2. The quick march can be maintained for long periods and is the standard for manoeuvring bodies of personnel.
3. The slow march is used on ceremonial occasions and its style emphasises dignity and stateliness.
4. Double time is used to move personnel rapidly from one point to another and for physical exercise.
5. During training, proper timing shall be enforced by having trainees call out cadences and the timing of drill movements.

PACE LENGTHS AND CADENCES

6. Marching pace lengths, as measured from the heel of the rear foot to the heel of the front foot, are:
 - (1) quick and slow time - 75 cm. (approximately 30 inches)
 - (2) stepping out in quick and slow time - 85 cm. (approximately 33 inches)
 - (3) stepping short in quick and slow time - 55 cm. (approximately 21 inches)
 - (4) double time - 1 m. (approximately 40 inches)
7. Marching cadences are:
 - (1) quick time - 120 paces per minute (two paces per second)
 - (2) slow time - 60 paces per minute (one pace per second)
 - (3) double time - 180 paces per minute (three paces per second)

WORDS OF COMMAND

8. All commands to commence marching are given when personnel are at attention and are prefaced with the cautionary command BY THE LEFT(RIGHT)(CENTRE) to indicate the directing file; e.g., SQUAD, BY THE LEFT, QUICK – MARCH or PLATOON, BY THE RIGHT, DOUBLE – MARCH.
9. As illustrated in Figure 1-1, unless the directing flank is changed by special command, it is always:
 - (1) when advancing in line, the right flank
 - (2) when retiring in line, the left flank
 - (3) when in diagonal march to the front, the right flank and when in diagonal march to the rear, the left flank
 - (4) when in two or three files, the original front rank; e.g., when moving to the right, the dressing is by the left; when moving to the left, the dressing is by the right
10. Instructors marching to the right or in front of squads to demonstrate proper marching technique, pace length, and cadence may use BY THE RIGHT or BY THE CENTRE to indicate the squad should take its dressing from the instructor.

11. On the march, executive commands are given as the foot specified in the following list is on the ground:

Drill Movement	Foot
HALT (quick/double time)	left
HALT (slow time)	right
STEP OUT or STEP SHORT	left
MARK TIME	right
FORWARD	left
CHANGE STEP	right
TO THE RIGHT/LEFT/FRONT SALUTE	left
EYES RIGHT/LEFT/FRONT	left
RIGHT TURN/INCLINE/FORM	left
LEFT TURN/INCLINE/FORM	right
ABOUT TURN	right
CHANGE TO QUICK/SLOW/DOUBLE TIME	right
FORM SINGLE FILE FROM TWOS/THREES/IN LINE	right
REFORM TWOS/THREES/IN LINE FROM SINGLE FILE	right
OPEN/CLOSE ORDER	right

MARCHING AND HALTING IN QUICK TIME

12. The quick march is performed in a brisk and forceful manner.

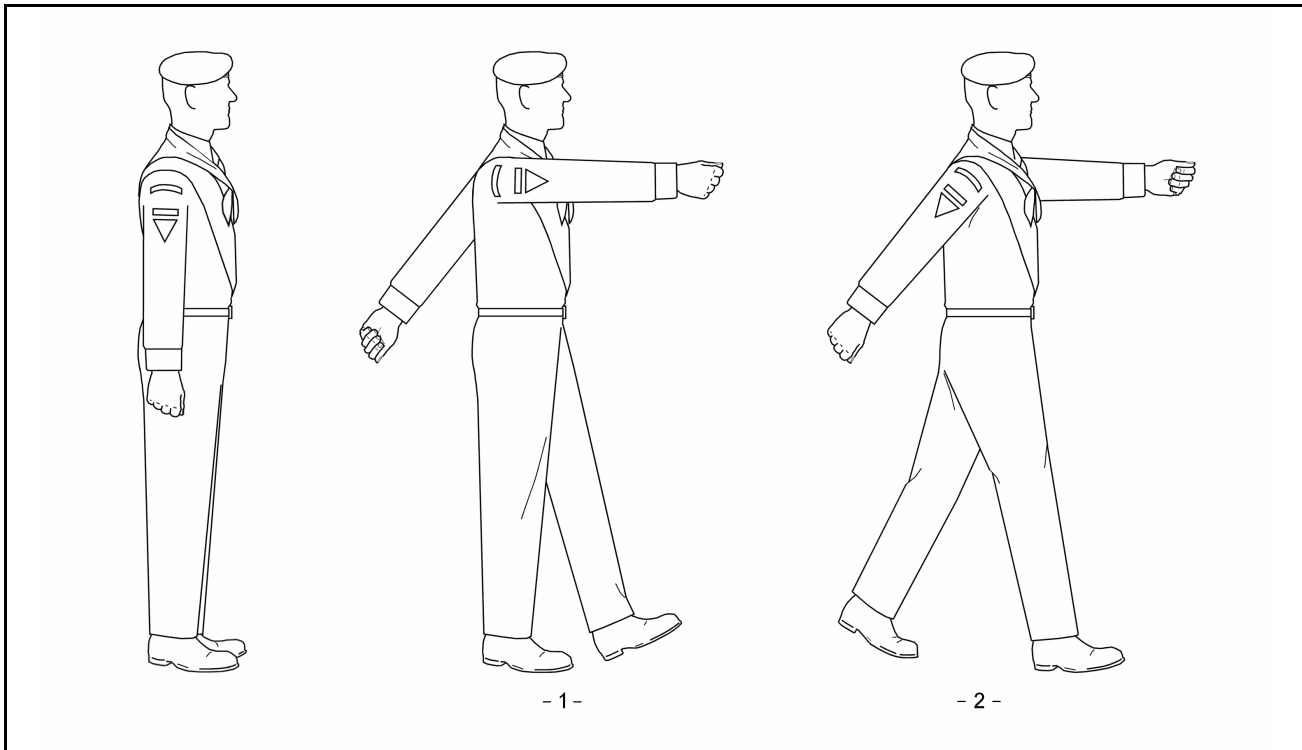

Figure 3-1: Marching in Quick Time

13. On the command QUICK MARCH BY NUMBERS, SQUAD – ONE, squad members shall (Figure 3-1):

- (1) shoot the left foot forward a half (35 cm.) pace in quick time, heel on the ground and toe up

- (2) simultaneously, swing the right arm straight forward shoulder high and the left arm straight backward waist high, keeping the arms straight and fists closed as for the position of attention
14. On the command SQUAD – TWO, squad members shall:
- (1) step forward with the right foot a standard length (75 cm.) pace in quick time, placing the foot flat on the ground with the weight on the right foot and the left heel raised
 - (2) simultaneously, swing the left arm forward shoulder high and the right arm backward waist high
 - (3) maintain dressing by the directing flank
15. Marching continues with the instructor alternating between the commands SQUAD – ONE and SQUAD – TWO. All subsequent paces shall be of standard length, with the weight on the front foot, and trainees shall keep cadence by calling out LEFT or RIGHT as the appropriate foot strikes the ground.
16. On the command QUICK – MARCH, the movements are combined in quick time. The squad shall indicate the cadence by calling out LEFT – RIGHT – LEFT for the first three paces.
17. While on the march, the instructor may keep the cadence by calling out LEFT – RIGHT – LEFT – RIGHT – LEFT – RIGHT – LEFT for eight paces, at varied intervals.
18. As an alternative to the instructor calling out the cadence, the squad may be ordered to perform a cadence count. On the command SQUAD, CADENCE – COUNT, given as the left foot is forward and on the ground, squad members shall take a further pace forward with the right foot then call out the cadence, as noted above, when the left foot next strikes the ground.
19. The command QUICK – MARCH shall be timed to ensure personnel step off in time with a band. To match step with another body of personnel already on the march, the cautionary command QUICK is given as the right feet of the marching group are on the ground and the executive command MARCH the next time the groups' right feet again strike the ground.

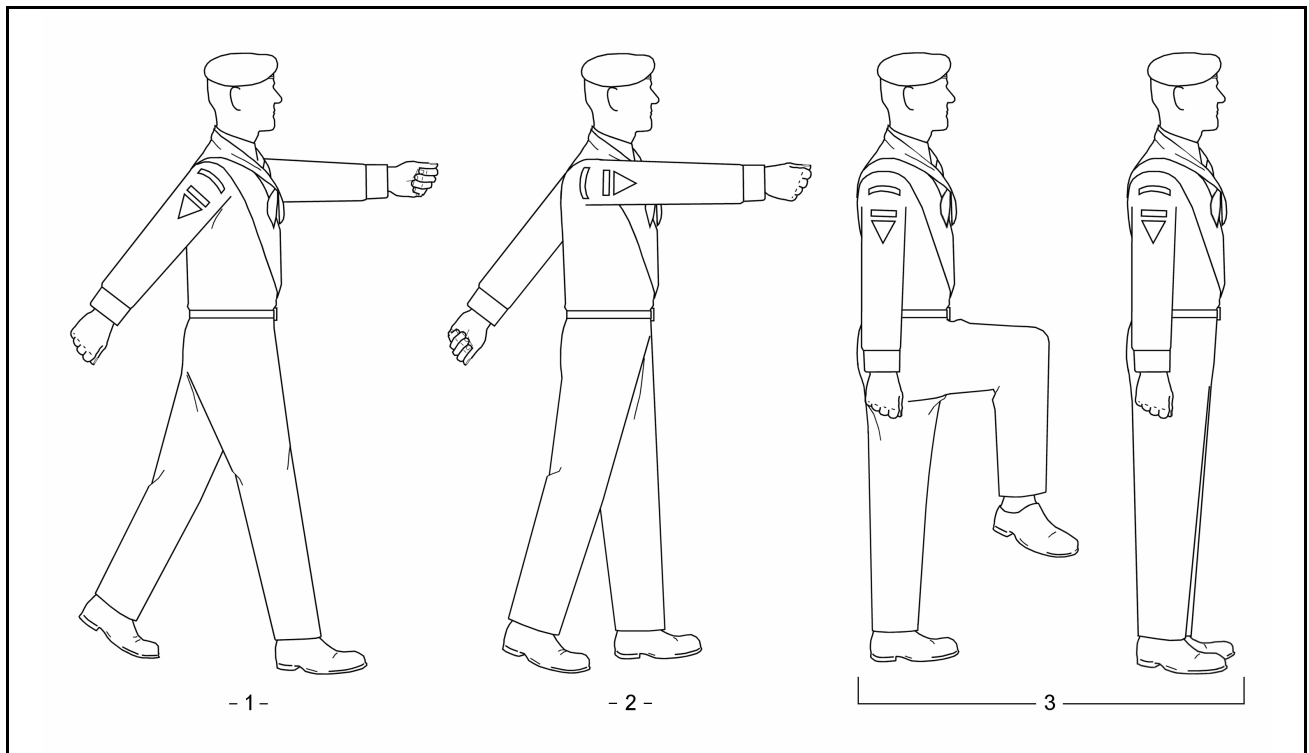

Figure 3-2: Halting in Quick Time

20. On the command HALT BY NUMBERS, SQUAD – ONE, given as the left foot is forward and on the ground, squad members shall (Figure 3-2):

- (1) take a standard (75 cm.) pace forward with the right foot in quick time, placing it flat on the ground, with the weight on the right foot and the left heel raised
- (2) simultaneously, swing the left arm forward and the right arm backward

21. On the command SQUAD – TWO, squad members shall:

- (1) take a half (35 cm.) pace forward with the left foot in quick time, placing it flat on the ground, with the weight on the left foot and the right heel raised
- (2) simultaneously, swing the right arm forward and the left arm backward

22. On the command SQUAD – THREE, squad members shall:

- (1) in quick time, bend the right knee so that the thigh is parallel to the ground, then straighten the leg and place the right foot smartly beside the left
- (2) simultaneously, bring the arms sharply to the sides and assume the position of attention

23. On the command SQUAD – HALT, the three movements are combined in quick time. The timing is counted as ONE – ONE – TWO.

MARCHING AND HALTING IN SLOW TIME

24. The slow march develops balance and good carriage and is an integral part of Canadian Pathfinder ceremonial.

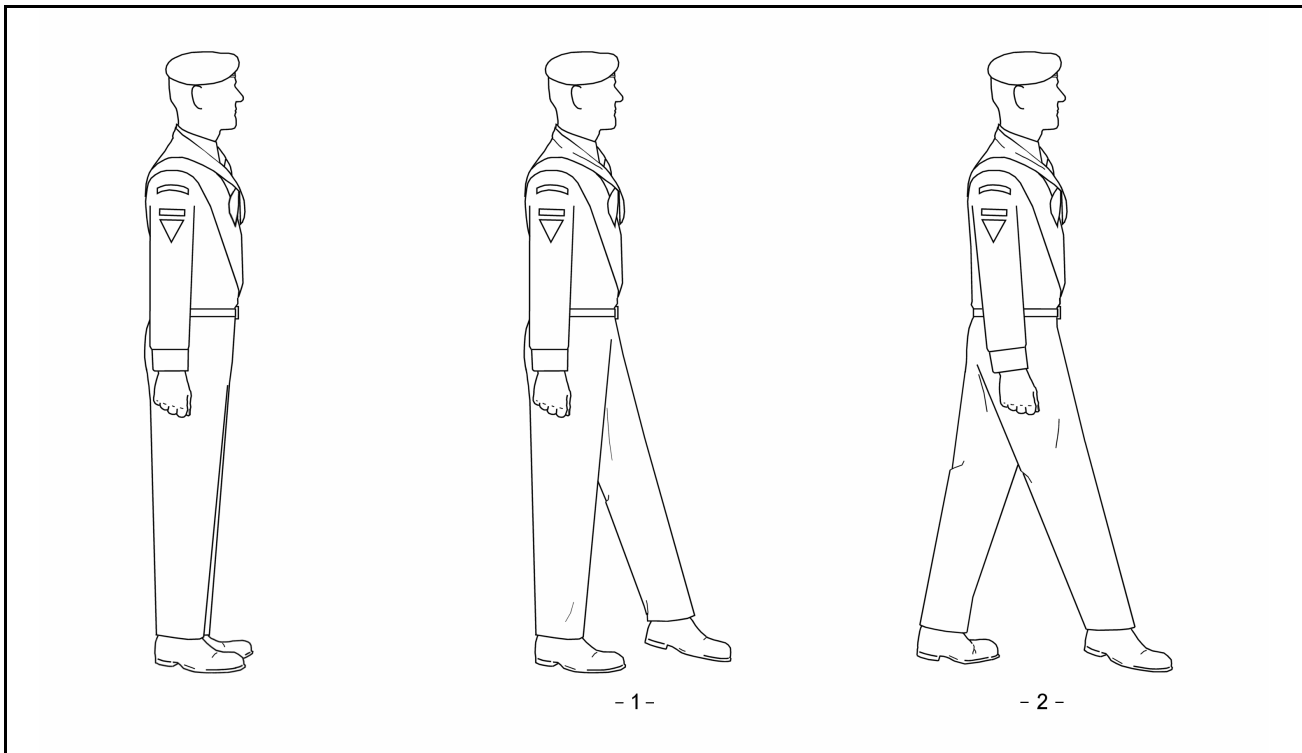

Figure 3-3: Marching in Slow Time

25. On the command SLOW MARCH BY NUMBERS, SQUAD – ONE, squad members shall (Figure 3-3):
- (1) extend the left foot forward a half (35 cm.) pace in slow time, toes pointing downward and just clear of the ground, with the left outer ankle turned slightly downward
 - (2) maintain the head and body erect and square to the front, arms straight at the sides
26. On the command SQUAD – TWO, squad members shall:
- (1) place the left foot flat on the ground, toe first, then glide the right foot forward a standard (75 cm.) pace in slow time with the foot positioned as described above, keeping the right leg as straight as possible and the weight on the left foot
 - (2) maintain dressing by the directing flank
27. Marching continues in this manner with the instructor alternating between the commands SQUAD – ONE and SQUAD – TWO. Trainees shall keep the cadence by calling out LEFT or RIGHT as the appropriate foot strikes the ground.
28. On the command SLOW – MARCH, the movements are combined in slow time. The squad shall indicate the cadence by calling out LEFT – RIGHT – LEFT for the first three paces.
29. While on the march, the instructor may keep the cadence by continually calling out LEFT – RIGHT as each foot strikes the ground.
30. Until balance and coordination are achieved, the slow march may be taught by having the squad stroll along at 60 paces per minute, with the toes of the front foot pointed down and the arms held behind the back, making sure consecutive paces are smooth and without hesitation. After further practice, the arms shall be held at the sides until the slow march is perfected.

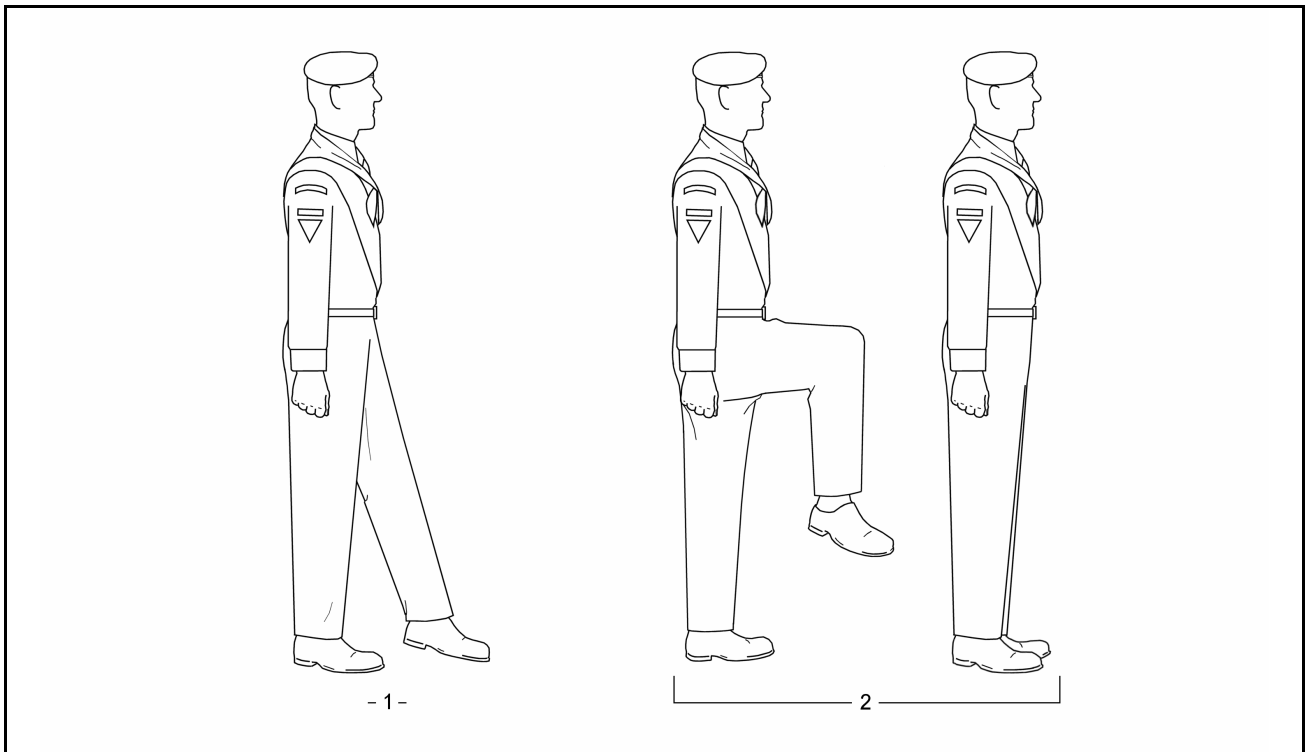

Figure 3-4: Halting in Slow Time

31. On the command HALT BY NUMBERS, SQUAD – ONE, given as the right foot is forward and on the ground, squad members shall take a half (35 cm.) pace forward with the left foot in slow time, placing the toe of the left foot on the ground and keeping the weight on the right foot (Figure 3-4).

32. On the command SQUAD – TWO, squad members shall:

- (1) shift the weight to the left foot
- (2) in quick time, bend the right knee so that the thigh is parallel to the ground then straighten the leg, placing the right foot smartly beside the left, and assume the position of attention

33. On the command SQUAD – HALT, the two movements are combined in slow and quick time. The timing is counted as ONE – TWO.

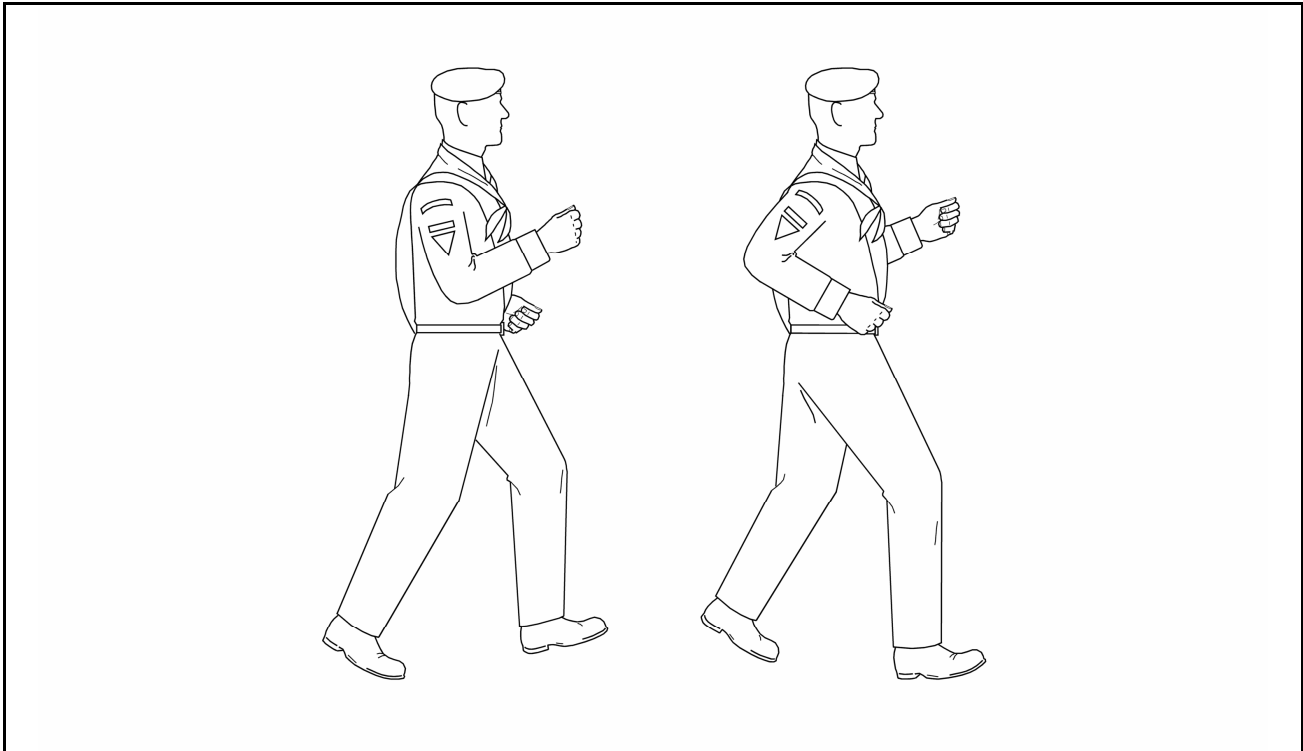

Figure 3-5: Marching in Double Time

MARCHING AND HALTING IN DOUBLE TIME

34. On the command DOUBLE – MARCH, squad members shall (Figure 3-5):

- (1) step forward 1 m. with the left foot and jog on the balls of the feet with easy swinging strides, inclining the body slightly forward
- (2) raise the feet clear of the ground at each pace
- (3) bend the arms at the elbow and swing the arms naturally from the shoulder with the hands closed as for the position of attention
- (4) maintain dressing by the directing flank

35. The squad shall indicate the cadence by calling out LEFT – RIGHT – LEFT, in double time, for the first three paces.

36. While on the march, the instructor may keep the cadence by calling out LEFT – RIGHT – LEFT – RIGHT – LEFT – RIGHT – LEFT as each foot strikes the ground.
37. On the command SQUAD – HALT, given as the left foot is forward and on the ground, squad members shall:
- (1) complete two paces in double time
 - (2) bring the right foot to the left after the second pace and, simultaneously, drop the arms sharply to the sides and assume the position of attention
38. The timing is counted as ONE – ONE – TWO in double time.

STEPPING OUT AND STEPPING SHORT

39. Stepping out is used to increase, and stepping short to decrease, pace length without altering the cadence.
40. On the command STEP – OUT, given as the left foot is forward and on the ground, squad members shall:
- (1) take a standard (75 cm.) pace forward with the right foot then lengthen pace by 10 cm. (approximately 3 inches) as the left foot next strikes the ground
 - (2) continue to march with lengthened paces until the command QUICK – MARCH is ordered
41. On the command QUICK – MARCH, given as the left foot is forward and on the ground, the pace will be shortened to the standard length when the left foot next strikes the ground.
42. On the command STEP – SHORT, given as the left foot is forward and on the ground, squad members shall:
- (1) take a standard (75 cm.) pace forward with the right foot then shorten pace by 20 cm. (approximately 9 inches) as the left foot next strikes the ground
 - (2) the squad shall continue to march with shortened paces until the command QUICK – MARCH is ordered
43. On the command QUICK – MARCH, given as the left foot is forward and on the ground, the pace will be lengthened to the standard length when the left foot next strikes the ground.
44. No timing or cadence is counted when stepping out or stepping short.

MARK TIME, FORWARD AND HALT FROM THE MARK TIME IN QUICK TIME

45. Marking time is used to keep a squad in one place while marching.
46. The cadence for marking time in quick time is the same as for quick march (120 paces per minute).
47. When marking time, the upper portion of the body remains in the position of attention, with the arms kept straight at the sides, and only the legs are moved.
48. On the command MARK TIME BY NUMBERS, SQUAD – ONE, given as the right foot is forward and on the ground, squad members shall (Figure 3-6):
- (1) take a half (35 cm.) pace forward with the left foot in quick time, placing it flat on the ground, with the weight on the left foot and the right heel raised
 - (2) simultaneously, swing the right arm forward and the left arm backward

49. On the command SQUAD – TWO, squad members shall:
- (1) bring the right foot in to the left in quick time and in a straight-leg manner, foot not scraping the ground
 - (2) simultaneously, bring the arms sharply to the sides and assume the position of attention
50. On the command SQUAD – THREE, squad members shall:
- (1) bend the left knee so that the thigh is parallel to the ground, then straighten the leg placing the left foot on the ground beside the right
 - (2) raise the right knee and continue marking time until the command FOR – WARD or HALT is given
51. On the command MARK – TIME, the three movements are combined in quick time. The timing is counted as CHECK – IN – LEFT – RIGHT – LEFT.

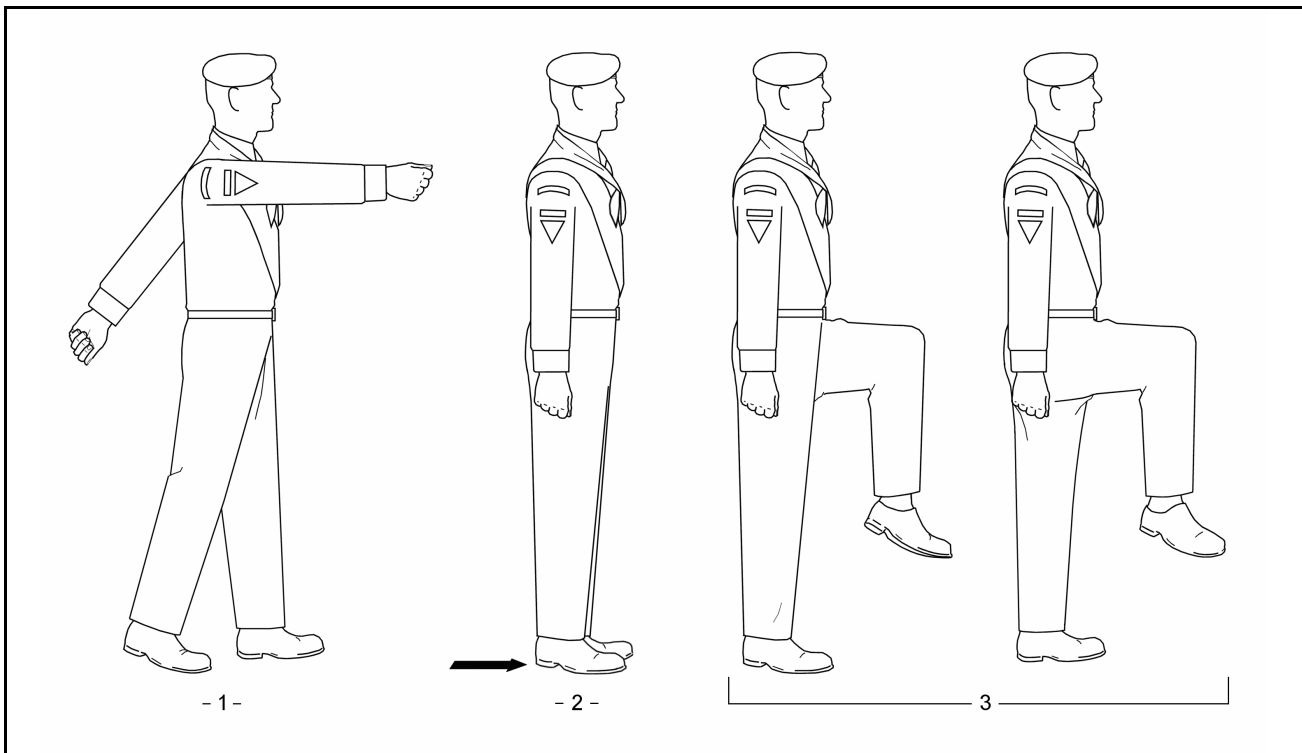

Figure 3-6: Marking Time in Quick Time

52. On the command FOR – WARD, given as the left foot is on the ground, squad members shall:
- (1) straighten the right leg
 - (2) as the right foot is placed flat on the ground, shoot the left foot forward a half (35 cm.) pace, swinging the right arm forward and the left arm backward
 - (3) take a standard (75 cm.) pace forward with the right foot, swinging the left arm forward and right arm backward, and continue marching in quick time
53. The timing is counted as CHECK – LEFT – RIGHT – LEFT in quick time.
54. On the command SQUAD – HALT, given as the left foot is on the ground, squad members shall:
- (1) take a further mark time pace with the right foot

- (2) take a further mark time pace with the left foot
- (3) straighten the right leg and assume the position of attention

- 55. The timing is counted as ONE – ONE – TWO in quick time.
- 56. To mark time from the halt, the command shall be QUICK MARK – TIME.

MARK TIME, FORWARD AND HALT FROM THE MARK TIME IN SLOW TIME

- 57. Marking time in slow time is carried out at the same cadence as for slow march (60 paces per minute).
- 58. When marking time, the upper portion of the body remains in the position of attention, with the arms kept straight at the sides, and only the legs are moved.
- 59. On the command MARK TIME BY NUMBERS, SQUAD – ONE, given as the right foot is forward and on the ground, squad members shall take a half (35 cm.) pace forward with the left foot in slow time, placing the toe of the left foot on the ground and keeping the weight on the right foot (Figure 3-7).
- 60. On the command SQUAD – TWO, squad members shall:
 - (1) shift the weight to the left foot
 - (2) bring the right foot in to the left in slow time and in a straight-leg manner, foot not scraping the ground, and assume the position of attention
- 61. On the command SQUAD – THREE, squad members shall:
 - (1) bend the left knee so that the thigh is parallel to the ground, then straighten the leg placing the left foot on the ground beside the right
 - (2) raise the right knee and continue marking time until the command FOR – WARD or HALT is given

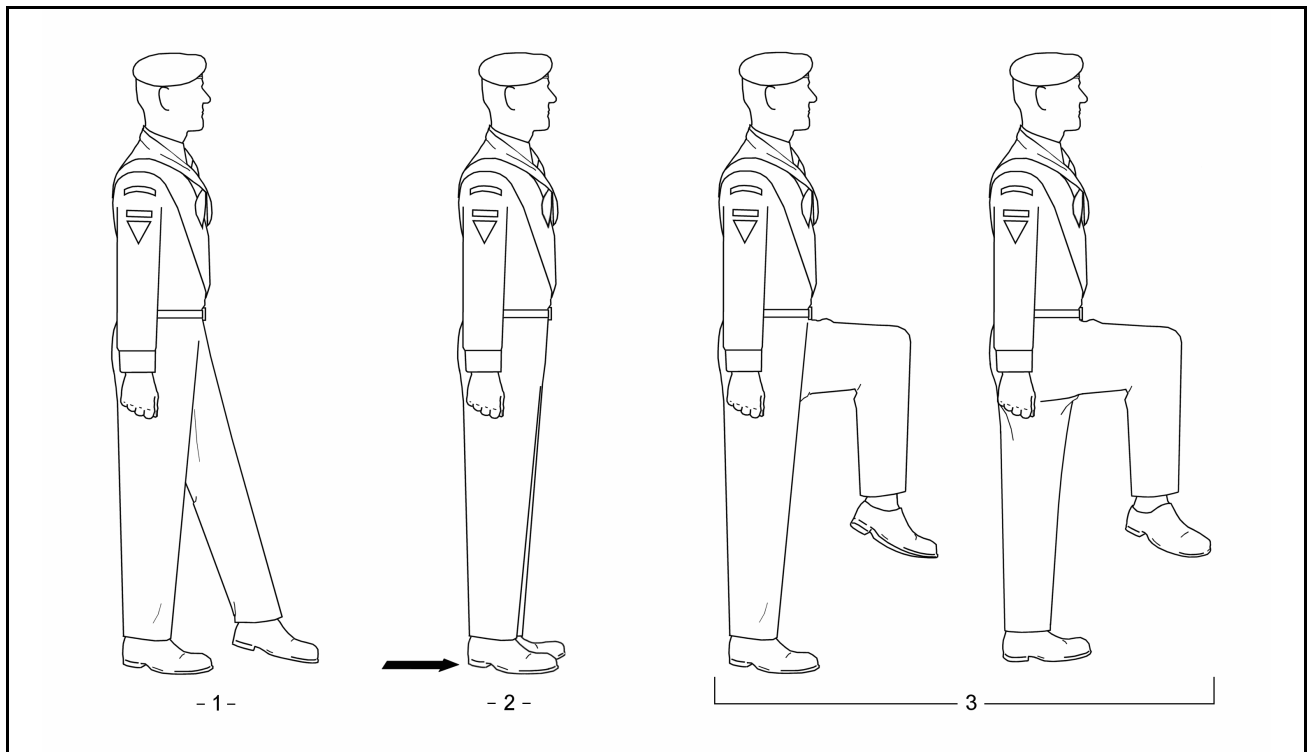

Figure 3-7: Marking Time in Slow Time

62. On the command MARK – TIME, the three movements are combined in slow time. The timing is counted as CHECK – IN – LEFT – RIGHT – LEFT.
63. On the command FOR – WARD, given as the left foot is on the ground, squad members shall:
- (1) straighten the right leg
 - (2) as the right foot is placed flat on the ground, shoot the left foot forward a half (35 cm.) pace, toe just clear of the ground
 - (3) take a standard (75 cm.) pace forward with the right foot and continue marching in slow time
64. The timing is counted as CHECK – LEFT – RIGHT – LEFT in slow time.
65. On the command SQUAD – HALT, given as the right foot is on the ground, squad members shall:
- (1) take a further mark time pace with the left foot
 - (2) straighten the right leg in quick time and assume the position of attention
66. The timing is counted as ONE – TWO in slow and quick time.
67. To mark time from the halt, the command shall be SLOW MARK – TIME.

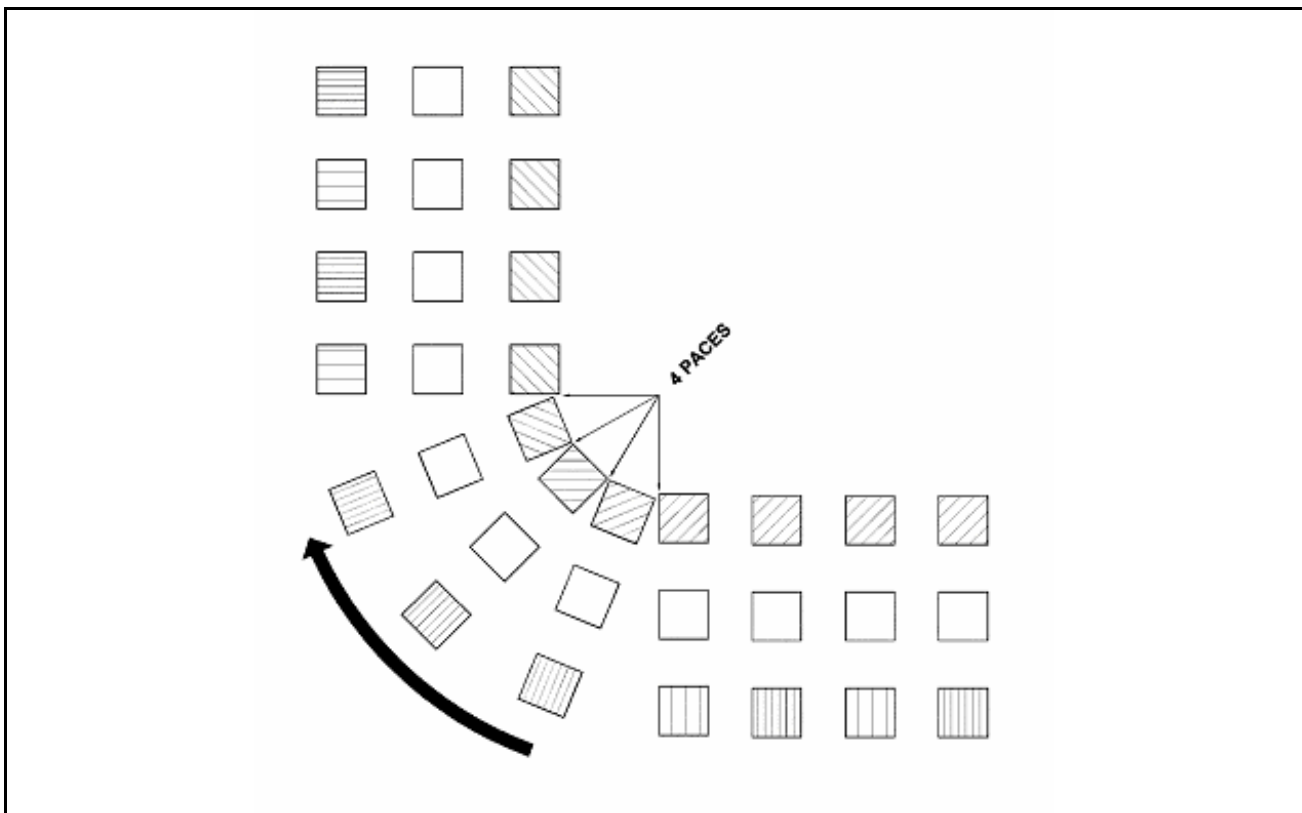

Figure 3-8: Wheeling

WHEELING

68. Wheels are used to change direction on the march, usually by 90 degrees, without altering the shape of the formation.

69. Squad members shall continue to keep their heads and eyes straight ahead and swing their arms throughout the wheel.

70. On the command RIGHT (LEFT) – WHEEL, the leading file wheels 90 degrees in the required direction, changing direction by 22.5 degrees on each pace; i.e., by the second pace the file will have changed direction by 45 degrees and be halfway through the wheel. The remaining files shall follow the lead file, wheeling at exactly the same point as the leading file (Figure 3-8).

71. Dressing is maintained by the inner flank while wheeling. During the wheel, the inner flank shall step short and the outer flank shall step out, without altering the cadence, to enable the file to maintain its dressing.

72. As each file completes the wheel it shall resume the normal pace length. Once the entire squad has completed the wheel, the directing flank shall be confirmed or indicated by order BY THE RIGHT (LEFT).

73. If the squad is ordered to halt or mark time, and only part of the squad has completed the wheel, the squad shall remain in position unless the command REAR FILES – COVER, is ordered. On the command REAR FILES – COVER, the files at the rear cover off behind the files that are facing the new direction.

74. When it is desired to wheel less than an angle of 90 degrees, the command FOR – WARD is ordered when the leading file faces the required direction.

CHANGING INDIVIDUAL STEP ON THE MARCH

75. When in quick, slow, or double time, individuals out-of-step with their squads can fall into step by quickening or slowing pace until synchronised.

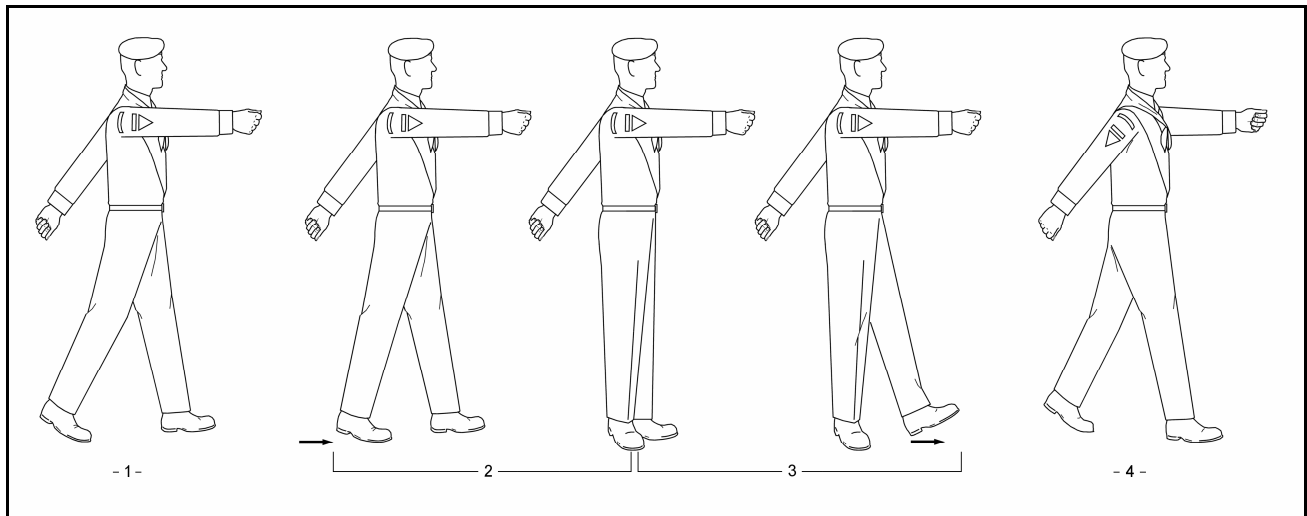

Figure 3-9: Changing Individual Step in Quick Time

76. Alternatively, the following method may be used by individuals to change step in quick time (Figure 3-9):

- (1) complete a full marching pace
- (2) without moving either the front foot or the arms, swiftly bring the inside edge of the rear foot up to meet the heel of the front foot
- (3) as the rear foot touches the front heel shoot the front foot forward a half (35 cm.) pace, heel on the ground, keeping the arms fixed in position
- (4) shift the weight to the front foot and step forward a standard (75 cm.) pace with the rear foot, swinging the rear arm forward and the front arm backward, and continue marching in quick time

CHANGING STEP AS A UNIT ON THE MARCH (OPTIONAL)

77. In quick time, on the command CHANGE STEP BY NUMBERS, SQUAD – ONE, given as the right foot is forward and on the ground, squad members shall (Figure 3-10):

- (1) take a half (35 cm.) pace forward with the left foot in quick time, placing it flat on the ground, with the weight on the left foot and the right heel raised
- (2) simultaneously, swing the right arm forward and the left arm backward

78. On the command SQUAD – TWO, squad members shall:

- (1) bring the arms sharply to the sides as for the position of attention
- (2) simultaneously, and in double time, bend the right knee so that the right foot is 15 cm. (approximately 6 inches) above the ground then straighten the leg, placing the right foot smartly beside the left
- (3) as the right foot strikes the ground, shoot the left foot forward a half (35 cm.) pace, landing on the heel with the toe up

79. On the command SQUAD – THREE, squad members shall take a standard (75 cm.) pace forward with the right foot, swinging the left arm forward and the right arm backward, and continue marching in quick time.

80. On the command CHANGE STEP, the three movements are combined. The timing is counted LEFT – RIGHT – LEFT in quick, double, then quick time, thus maintaining quick march cadence while changing step.

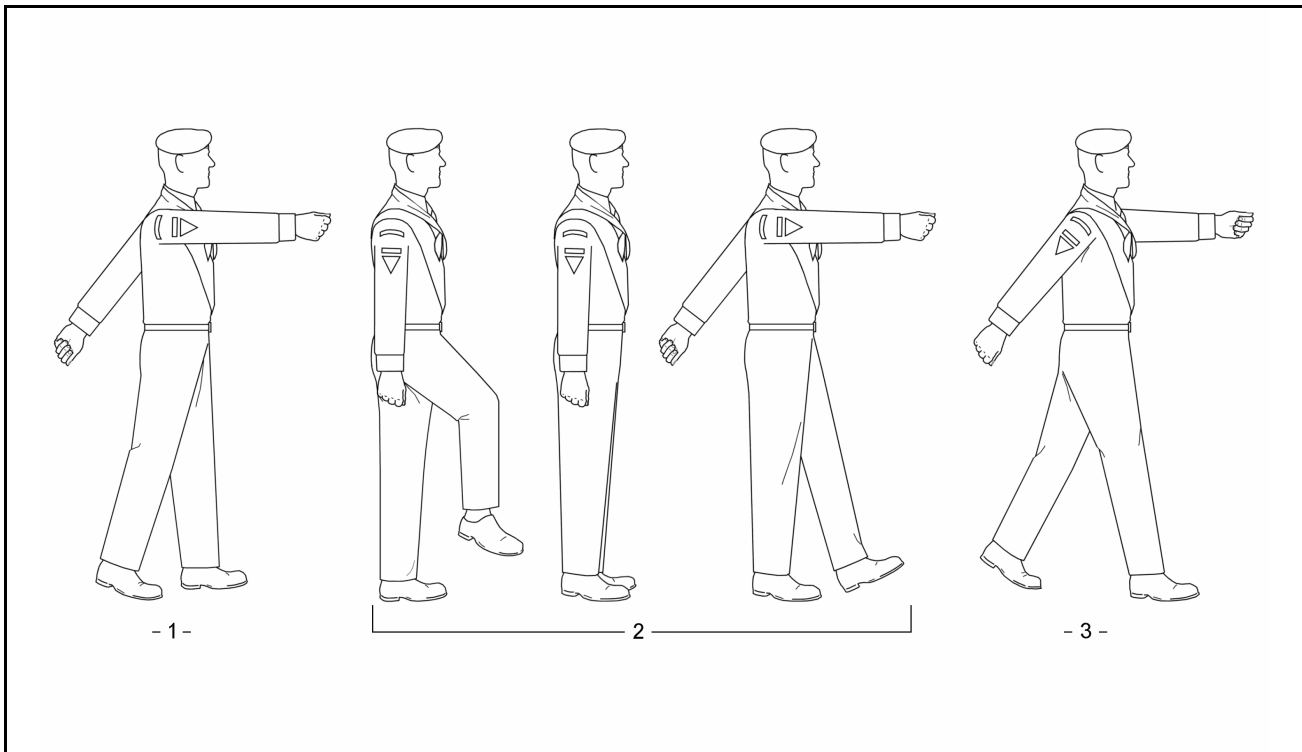

Figure 3-10: Changing Step as a Unit in Quick Time

81. In slow time, on the command CHANGE STEP BY NUMBERS, SQUAD – ONE, given as the right foot is forward and on the ground, squad members shall take a half (35 cm.) pace forward with the left foot in slow time, placing the toe of the left foot on the ground and keeping the weight on the right foot (Figure 3-11).

82. On the command SQUAD – TWO, squad member shall:
- (1) shift the weight to the left foot
 - (2) in quick time, bend the right knee so that the thigh is parallel to the ground, then straighten the right leg, placing the right foot smartly beside the left
 - (3) as the right foot strikes the ground, shoot the left foot forward a half (35 cm.) pace, toe on the ground and with the weight on the right foot
83. On the command SQUAD – THREE, squad members shall take a standard (75 cm.) pace forward with the right foot and continue marching in slow time.
84. On the command CHANGE – STEP, the three movements are combined. The timing is counted as LEFT – RIGHT – LEFT in slow, quick, then slow time, thus maintaining slow march cadence while changing step.

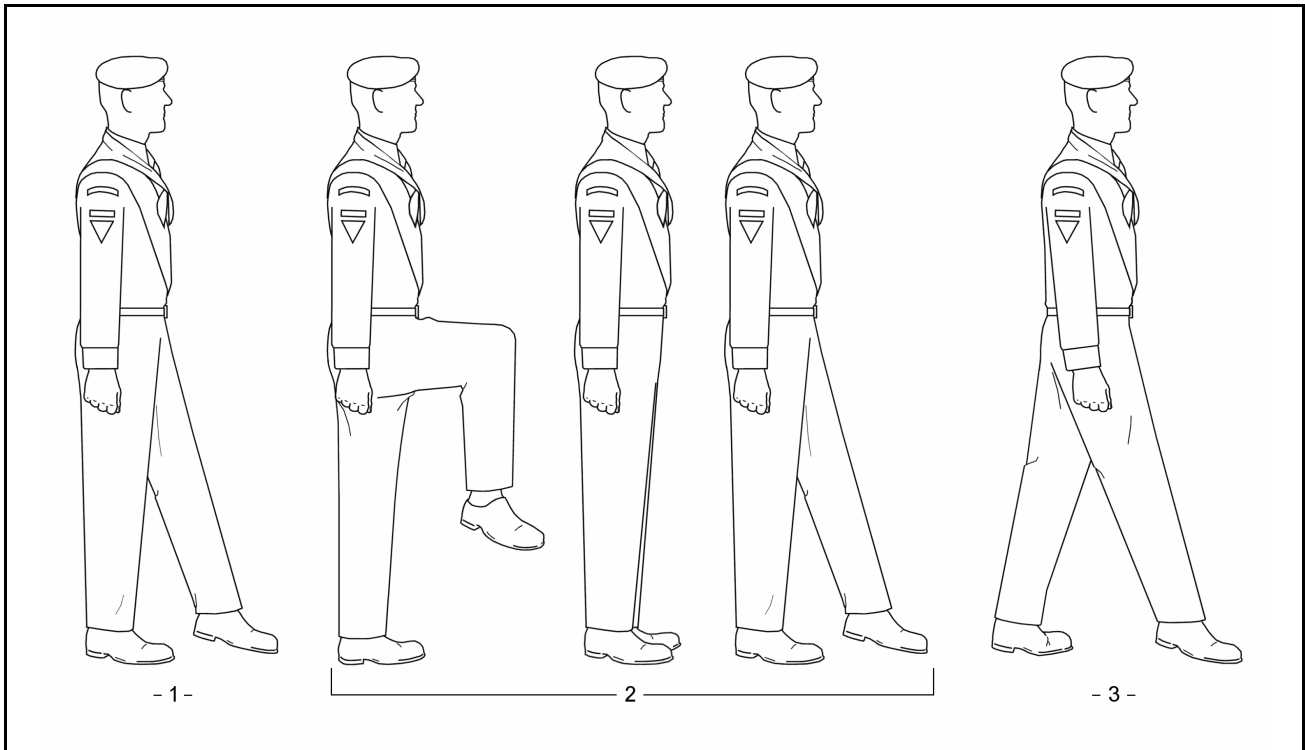

Figure 3-11: Changing Step as a Unit in Slow Time

CHANGING STEP WHEN MARKING TIME

85. On the command CHANGE – STEP, given as the right foot is on the ground, squad members shall take two mark time paces with the left foot then raise the right leg and continue marking time.
86. The timing is counted as LEFT – LEFT – RIGHT in the same cadence as marking time.

FORMING A HOLLOW SQUARE

87. The hollow square allows drill instructors to be seen at all times by all members of a squad.
88. The squad shall be formed up in three ranks and in line prior to forming a hollow square.
89. On the command FORM HOLLOW SQUARE, CENTRE RANK RIGHT, REAR RANK LEFT – TURN, the ranks shall act as ordered (Figure 3-12). The timing is counted as ONE – TWO – THREE – ONE.

90. On the command CENTRE RANK LEFT WHEEL, REAR RANK RIGHT WHEEL, QUICK – MARCH, the ranks shall act as ordered. The cadence is counted as LEFT – RIGHT – LEFT.
91. The command MARK – TIME shall be given when the last person in each of the centre and rear ranks is one pace in front of the front rank. The timing is counted as CHECK – IN – LEFT – RIGHT – LEFT.
92. On the command SQUAD – HALT, the centre and rear ranks shall halt. The timing is counted as ONE – ONE – TWO.
93. On the command CENTRE RANK LEFT, REAR RANK RIGHT – TURN, the ranks shall act as ordered. The timing is counted as ONE – TWO – THREE – ONE.
94. The reverse procedure is used to reform the squad into three ranks.

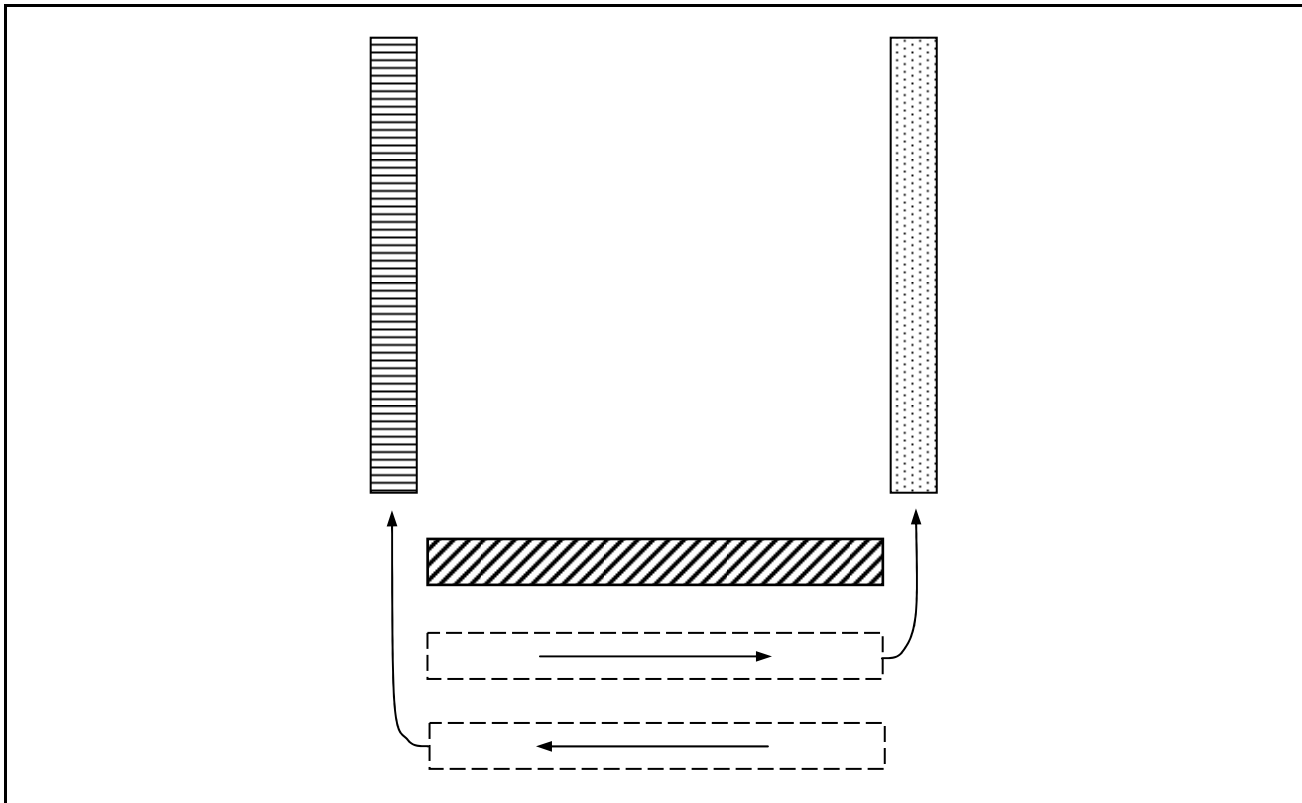

Figure 3-12: Forming a Hollow Square

SALUTING ON THE MARCH

95. The arm movements for saluting on the march shall be executed as for saluting at the halt.
96. When a member of the Pathfinder organisation salutes on the march, he shall commence the salute five paces before reaching an officer, look directly into the officer's eyes by turning his head in the required direction on commencing the salute, and complete the salute one pace beyond. This permits the officer time to return the salute before the member has passed.
97. On the command TO THE FRONT (RIGHT) (LEFT) SALUTE BY NUMBERS, SQUAD – ONE, given as the left foot is forward and on the ground, squad members shall take a standard (75 cm.) pace forward with the right foot, swinging the left arm forward and the right arm backward (Figure 3-13).
98. On the command SQUAD – TWO, squad members shall:
 - (1) take a standard (75 cm.) pace with the left foot

(2) simultaneously, bring the left arm down sharply to the side and the right arm forward, first to the side of the body, then up into the salute, and

(3) turn the head sharply in the appropriate direction if saluting to the right or left

99. The salute shall be timed so that it is completed as the left foot is placed flat on the ground.

100. On the command SQUAD – THREE, squad members shall complete four standard paces in quick time, keeping the left arm straight at the side and maintaining the salute.

101. On the command SQUAD – FOUR, squad members shall:

(1) take a standard (75 cm.) pace with the right foot

(2) simultaneously, bring the right arm down sharply to the side, and

(3) turn the head sharply to the front if the salute was to the right or left

102. On the command SQUAD – FIVE, squad members shall take a standard (75 cm.) pace with the left foot, swinging the right arm forward and the left arm backward, and continue marching in quick time.

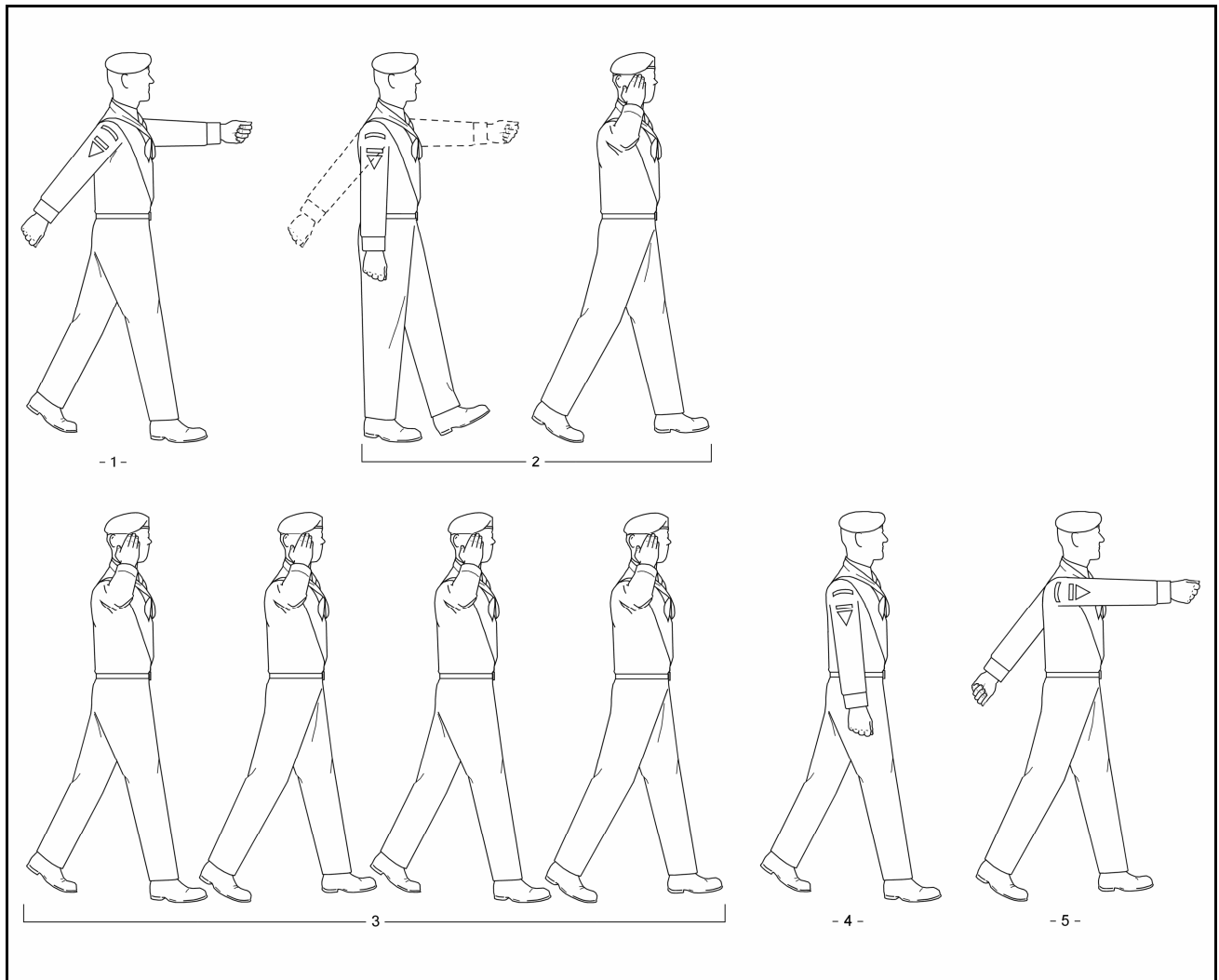

Figure 3-13: Saluting on the March

103. On the command TO THE FRONT (LEFT) (RIGHT) – SALUTE, the five movements are combined in quick time. The timing is counted as CHECK – UP – TWO – THREE – FOUR – FIVE – DOWN – SWING.

PAYING UNIT COMPLIMENTS ON THE MARCH

104. On the command EYES RIGHT (LEFT) BY NUMBERS, SQUAD – ONE, given as the left foot is forward and on the ground, squad members shall take a standard (75 cm.) pace forward with the right foot, swinging the left arm forward and the right arm backward.

105. On the command SQUAD – TWO, the squad shall:

- (1) take a standard (75 cm.) pace with the left foot, swinging the right arm forward and the left arm backward
- (2) as the left foot strikes the ground, all except the marker shall turn their head and eyes sharply to the right (left) as far as possible without straining and look directly into the eyes of the person being saluted
- (3) the person in command of the squad salutes in accordance with the directions for saluting on the march

106. On the command EYES – RIGHT (LEFT), the two movements are combined in quick time. The timing is counted as CHECK – OVER.

107. On the command EYES FRONT NUMBERS, SQUAD – ONE, given as the left foot is forward and on the ground, squad members shall take a standard (75 cm.) pace with the right foot, swinging the left arm forward and the right arm backward.

108. On the command SQUAD – TWO, the squad shall:

- (1) take a standard pace with the left foot, swinging the right arm forward and the left arm backward
- (2) as the left foot strikes the ground, all except the marker shall turn their head and eyes sharply to the front
- (3) the person in command of the squad brings his right arm down sharply to the side then swings his arms on the next left foot

109. On the command EYES – FRONT, the two movements are combined in quick time. The timing is counted as CHECK – FRONT.

TURNING AND INCLINING TO THE RIGHT (LEFT) ON THE MARCH IN QUICK TIME

110. Turns and inclines on the march are executed to change direction and formation.

111. On the command RIGHT TURN BY NUMBERS, SQUAD – ONE, given as the left foot is forward and on the ground, squad members shall (Figure 3-14):

- (1) take a half (35 cm.) pace forward with the right foot in quick time, placing it flat on the ground, with the weight on the right foot and the left heel raised
- (2) simultaneously, swing the left arm forward and the right arm backward

112. On the command SQUAD – TWO, squad members shall:

- (1) bring the arms sharply to the sides as for the position of attention
- (2) simultaneously, and in quick time, bend the left knee so that the thigh is parallel to the ground and, using the momentum of the knee, pivot on the ball of the right foot 90 degrees to the right

- (3) straighten the left leg in quick time, placing the left foot smartly beside the right and assume the position of attention

113. On the command SQUAD – THREE, squad members shall take a half (35 cm.) pace with the right foot, swinging the left arm forward and the right arm backward.

114. On the command SQUAD – FOUR, squad members shall take a standard (75 cm.) pace with the left foot, swinging the right arm forward and the left arm backward, and continue marching in quick time.

115. On the command RIGHT – TURN, the four movements are combined in quick time. The timing is counted as CHECK – PIVOT – RIGHT – LEFT – RIGHT.

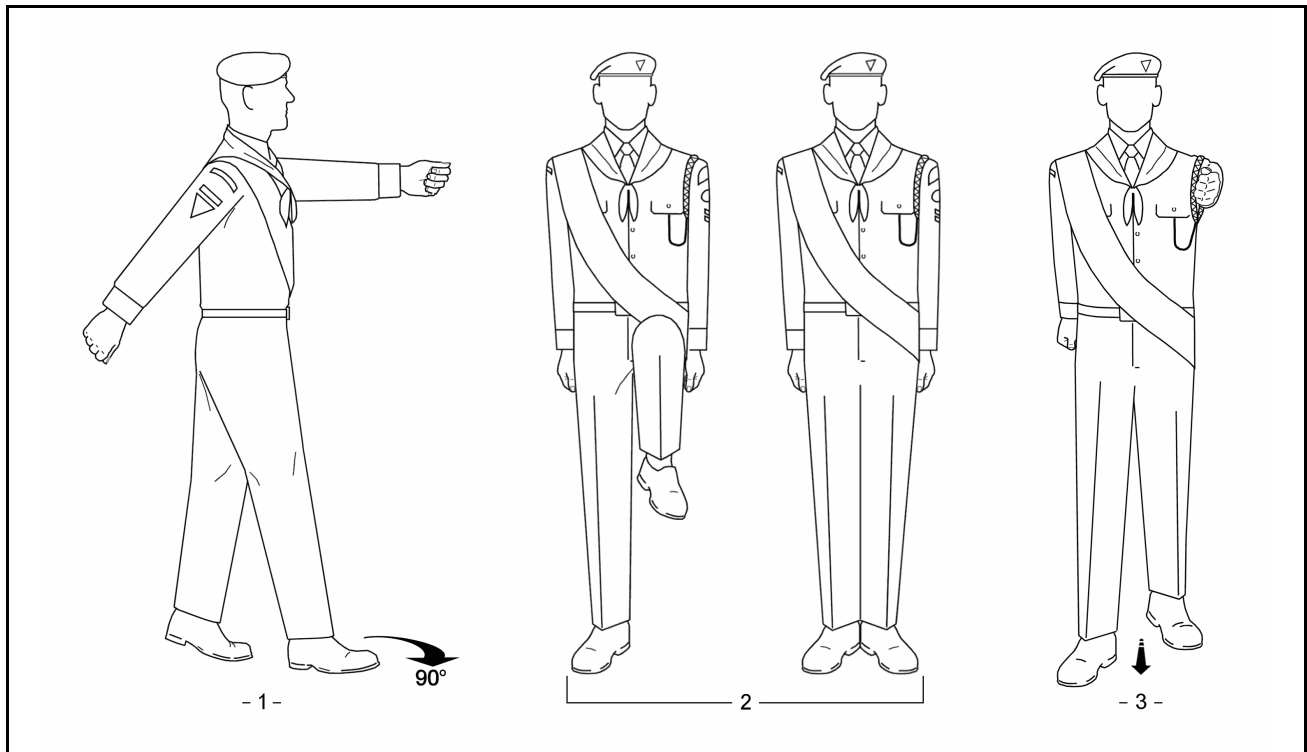

Figure 3-14: Right Turn in Quick Time

116. On the command RIGHT IN – CLINE, the drill is executed as for a right turn except the pivot is made through 45 degrees.

117. On the command LEFT TURN BY NUMBERS, SQUAD – ONE, called as the right foot is forward and on the ground, the drill is executed as for a right turn except the direction and details of moving the feet are reversed. The timing is counted as CHECK – PIVOT – LEFT – RIGHT – LEFT.

118. On the command LEFT IN – CLINE, the drill is executed as for a left turn except the pivot is made through 45 degrees.

TURNING AND INCLINING TO THE RIGHT (LEFT) ON THE MARCH IN SLOW TIME

119. On the command RIGHT TURN BY NUMBERS, SQUAD – ONE, given as the left foot is forward and on the ground, squad members shall take a half (35 cm.) pace forward with the right foot in slow time, toe on the ground and weight on the left foot (Figure 3-15).

120. On the command SQUAD – TWO, squad members shall:

- (1) shift the weight to the right foot

- (2) in slow time, bend the left knee so that the thigh is parallel to the ground and, using the momentum of the knee, pivot on the ball of the right foot 90 degrees to the right
- (3) straighten the left leg in slow time, placing the left smartly foot beside the right and assume the position of attention

121. On the command SQUAD – THREE, squad members shall take a half (35 cm.) with the right foot, toe just clear of the ground and weight on the left foot.

122. On the command SQUAD – FOUR, squad members shall:

- (1) shift the weight to the right foot
- (2) take a standard (75 cm.) pace with the left foot and continue marching in slow time

123. On the command RIGHT – TURN, the four movements are combined in slow time. The timing is counted as CHECK – PIVOT – RIGHT – LEFT – RIGHT.

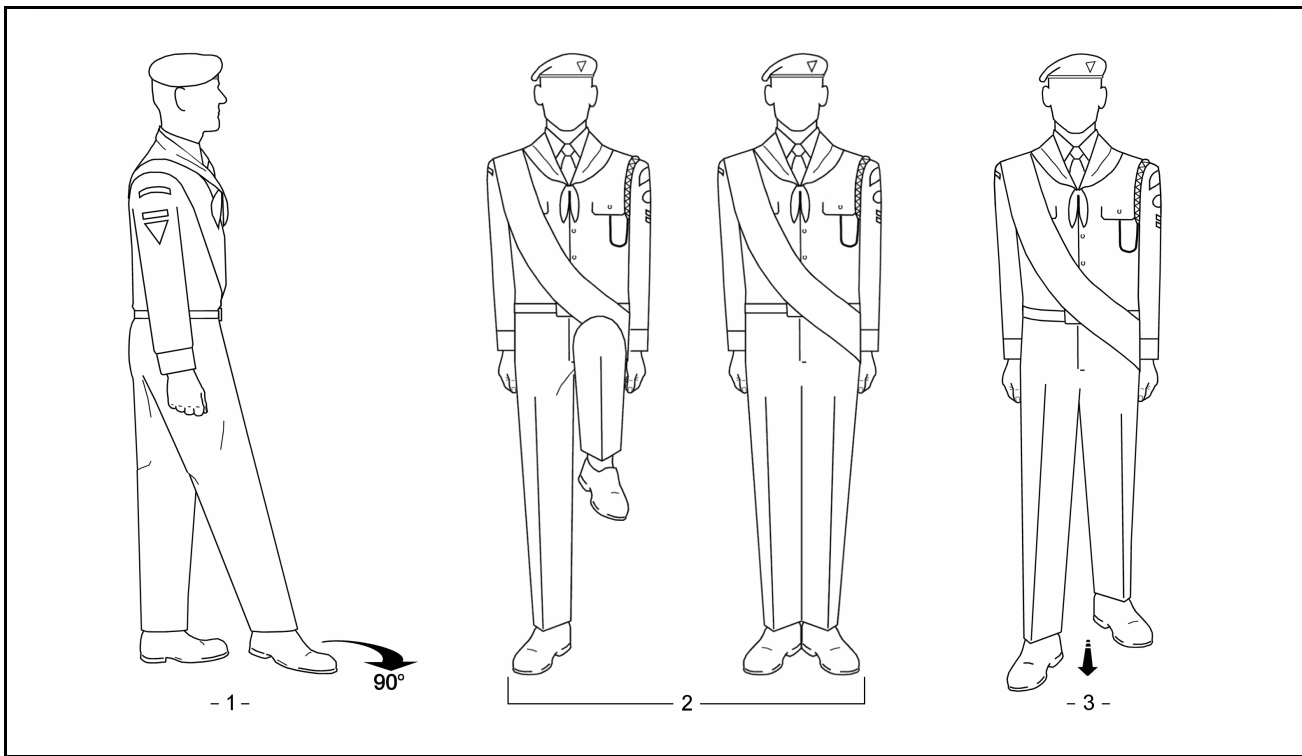

Figure 3-15: Right Turn in Slow Time

124. On the command RIGHT IN – CLINE, the drill is executed as for a right turn except the pivot is made through 45 degrees.

125. On the command LEFT TURN BY NUMBERS, SQUAD – ONE, called as the right foot is forward and on the ground, the drill is executed as for a right turn except the direction and details of moving the feet are reversed. The timing is counted as CHECK – PIVOT – LEFT – RIGHT – LEFT.

126. On the command LEFT IN – CLINE, the drill is executed as for a left turn except the pivot is made through 45 degrees.

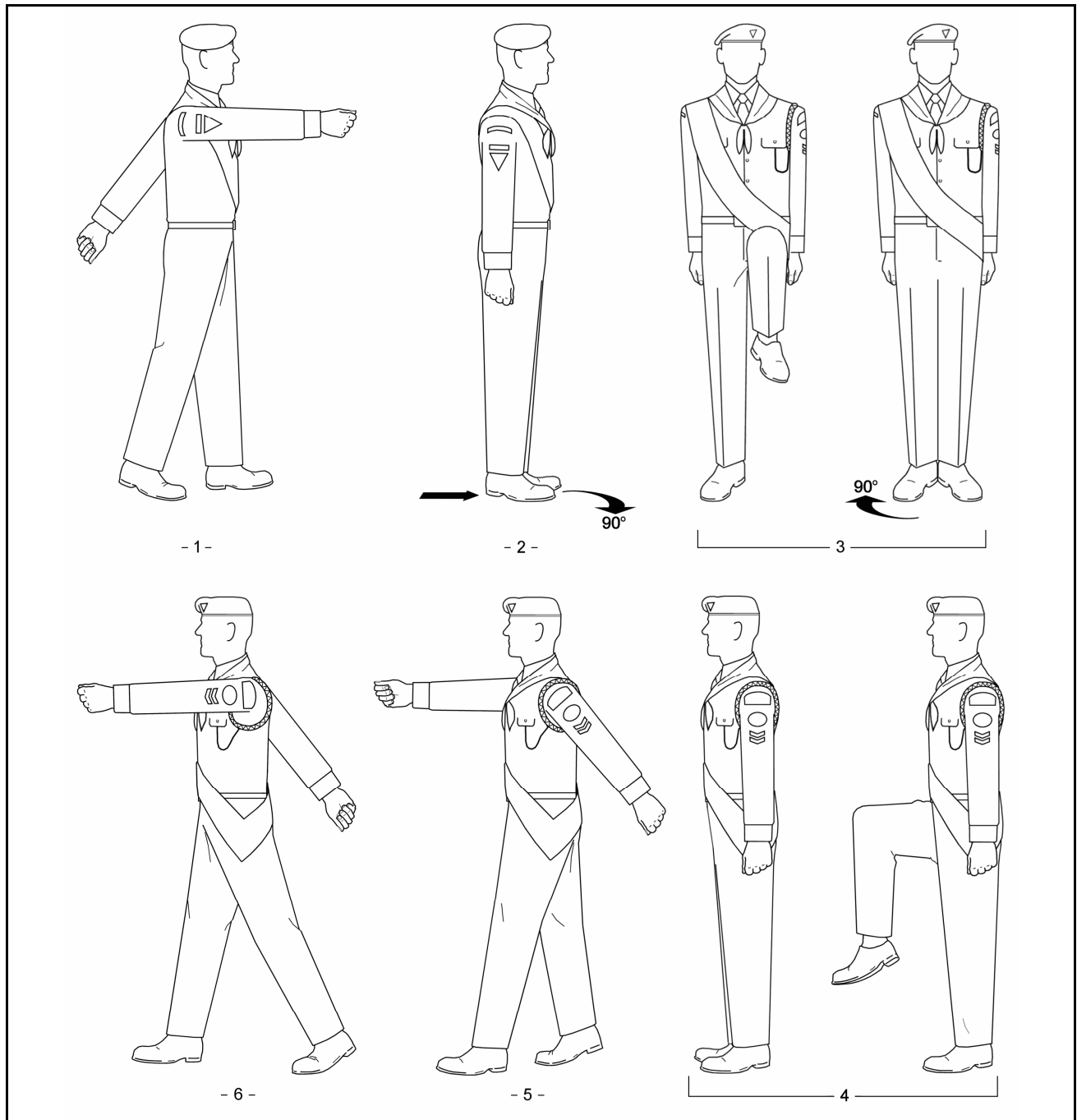

Figure 3-16: About Turn in Quick Time

TURNING ABOUT ON THE MARCH IN QUICK TIME

127. On the command ABOUT TURN BY NUMBERS, SQUAD – ONE, given as the right foot is forward and on the ground, squad members shall take a half (35 cm.) pace forward with the left foot, swinging the right arm forward and the left arm backward, with the weight on the left foot and the right heel raised (Figure 3-16).

128. On the command SQUAD – TWO, squad members shall:

- (1) bring the right foot in to the left in quick time and in a straight-leg manner, foot not scraping the ground

(2) simultaneously, bring the arms sharply to the sides and assume the position of attention

129. On the command SQUAD – THREE, squad members shall:

- (1) in quick time, bend the left knee so that the thigh is parallel to the ground and, using the momentum of the knee, pivot on the ball of the right foot 90 degrees to the right
- (2) straighten the left leg in quick time, placing the left foot smartly beside the right and assume the position of attention

130. On the command SQUAD – FOUR, squad members shall:

- (1) in quick time, bend the right knee so that the thigh is parallel to the ground and, using the momentum of the knee, pivot on the ball of the left foot 90 degrees to the right
- (2) straighten the right leg in quick time, placing the right foot smartly beside the left and assume the position of attention

131. On the command SQUAD – FIVE, squad members shall take a half (35 cm.) pace with the left foot, swinging the right arm forward and the left arm backward.

132. On the command SQUAD – SIX, squad members shall take a standard (75 cm.) pace with the right foot, swinging the left arm forward and the right arm backward, and continue marching in quick time.

133. On the command ABOUT – TURN, the six movements are combined in quick time. The timing is counted as CHECK – IN – PIVOT – PIVOT – LEFT – RIGHT – LEFT.

134. When a blank file with one person exists in a squad that is in line, the person shall step out after the about turn to take up position in the leading rank.

TURNING ABOUT ON THE MARCH IN SLOW TIME

135. On the command ABOUT TURN BY NUMBERS, SQUAD – ONE, given as the right foot is forward and on the ground, squad members shall take a half (35 cm.) pace forward with the left foot, toe on the ground and weight on the right foot (Figure 3-17).

136. On the command SQUAD – TWO, squad members shall:

- (1) shift the weight to the left foot
- (2) bring the right foot in to the left in slow time and in a straight-leg manner, foot not scraping the ground, and assume the position of attention

137. On the command SQUAD – THREE, squad members shall:

- (1) in slow time, bend the left knee so that the thigh is parallel to the ground and, using the momentum of the knee, pivot on the ball of the right foot 90 degrees to the right
- (2) straighten the left leg in slow time, placing the left foot beside the right and assume the position of attention

138. On the command SQUAD – FOUR, squad members shall:

- (1) bend the right knee so that the thigh is parallel to the ground, foot at a natural angle
- (2) using the momentum of the knee, pivot on the ball of the left foot 90 degrees to the right
- (3) straighten the right leg in slow time, placing the right foot smartly beside the left and assume the position of attention

139. On the command SQUAD – FIVE, squad members shall take a half (35 cm.) pace with the left foot, toe on the ground and the weight on the right foot.

140. On the command SQUAD – SIX, squad members shall take a standard (75 cm.) pace with the right foot and continue marching in slow time.

141. On the command ABOUT – TURN, the six movements are combined in slow time. The timing is counted as CHECK – IN – PIVOT – PIVOT – LEFT – RIGHT – LEFT.

142. When a blank file with one person exists in a squad that is in line, the person shall step out after the about turn to take up position in the leading rank.

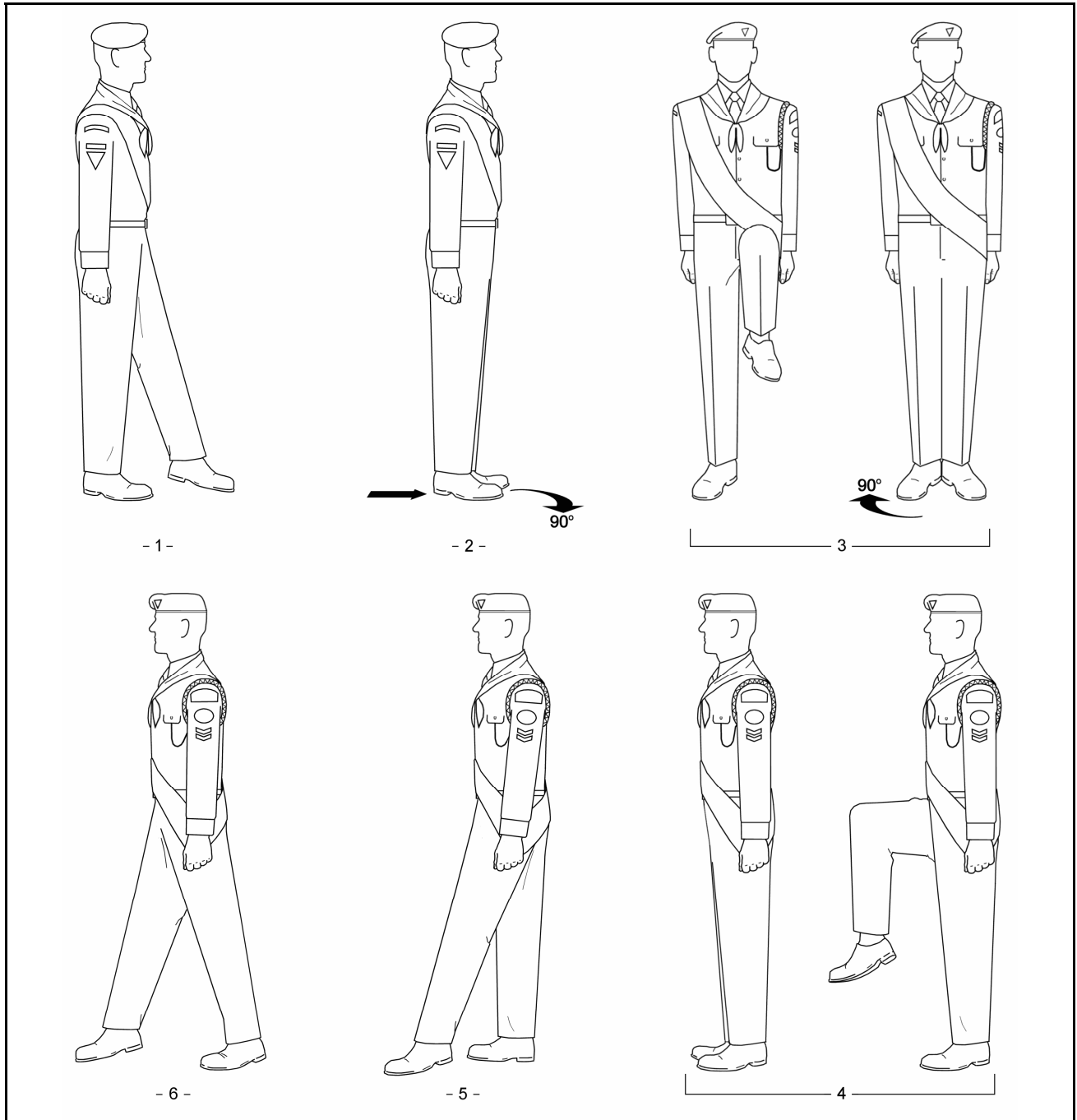

Figure 3-17: About Turn in Slow Time

CHANGING TO SLOW TIME FROM QUICK TIME

143. On the command CHANGE TO SLOW TIME, SLOW MARCH BY NUMBERS, SQUAD – ONE, given as the right foot is forward and on the ground, squad members shall take a half (35 cm.) pace forward in quick time with the left foot, swinging the right arm forward and the left arm backward, with the weight on the left foot and the right heel raised.

144. On the command SQUAD – TWO, squad members shall:

- (1) bring the arms sharply to the sides
- (2) simultaneously, and in quick time, bend the right knee so that the thigh is parallel to the ground then straighten the leg in quick time, placing the right foot smartly beside the left and assume the position of attention

145. On the command SQUAD – THREE, squad members shall take a half (35 cm.) pace forward in slow time with the left foot, toe just above the ground and weight on the right foot.

146. On the command SQUAD – FOUR, squad members shall:

- (1) shift the weight to the left foot
- (2) take a standard (75 cm.) pace forward with the right foot and continue marching in slow time

147. On the command CHANGE TO SLOW TIME, SLOW – MARCH, the four movements are combined. The timing is counted as LEFT – RIGHT – LEFT in quick and slow time.

CHANGING TO QUICK TIME FROM SLOW TIME

148. On the command CHANGE TO QUICK TIME, QUICK – MARCH, given as the right foot is forward and on the ground, squad members shall step forward with the left foot in quick time, swinging the right arm forward and the left arm backward, and continue marching in quick time.

CHANGING TO DOUBLE TIME FROM QUICK TIME

149. On the command CHANGE TO DOUBLE TIME, DOUBLE – MARCH, given as the right foot is forward and on the ground, squad members shall step forward with the left foot in double time, with the arms in the position as for double time, and continue marching in double time.

CHANGING TO QUICK TIME FROM DOUBLE TIME

150. On the command CHANGE TO QUICK TIME, QUICK – MARCH, given as the right foot is forward and on the ground, squad members shall shorten pace to the standard quick march length while completing four paces in double time, then continue marching in quick time.

CHANGING DIRECTION BY FORMING FROM THE HALT (OPTIONAL)

151. A form changes the direction of a squad that is in line by 90 degrees while maintaining its formation.

152. To change direction by forming from the halt to the halt, on the command AT THE HALT, CHANGE DIRECTION RIGHT, RIGHT – FORM (Figure 3-18):

- (1) the marker turns right
- (2) the squad commander and remainder of the front rank incline right
- (3) the centre and rear ranks stand fast

153. On the command QUICK – MARCH:

- (1) the marker marches forward five paces in quick time then halts
- (2) the remainder of the squad marches in quick time, wheeling right as necessary to maintain straight ranks, with squad members in the centre and rear ranks following those directly in front in their respective files
- (3) upon reaching its new position each file shall halt facing the new direction, in succession from right to left, and remain at attention

154. To change direction by forming from the halt to the mark time, on the command CHANGE DIRECTION RIGHT, RIGHT – FORM, the squad shall execute the drill as for forming to the right at the halt.

155. On the command QUICK – MARCH:

- (1) the marker marches forward five paces in quick time then begins marking time
- (2) the remainder of the squad marches in quick time, wheeling right as necessary to maintain straight ranks, with squad members in the centre and rear ranks following those directly in front in their respective files
- (3) upon reaching its new position each file shall begin marking time facing the new direction, in succession from right to left

156. Upon completion of the movement, the squad will be in line and facing 90 degrees from its previous facing.

157. On the command FOR – WARD or SQUAD – HALT, the squad shall act as ordered.

158. Changing direction by forming to the left is executed as for forming to the right except the details are reversed and the marker becomes the front-left person.

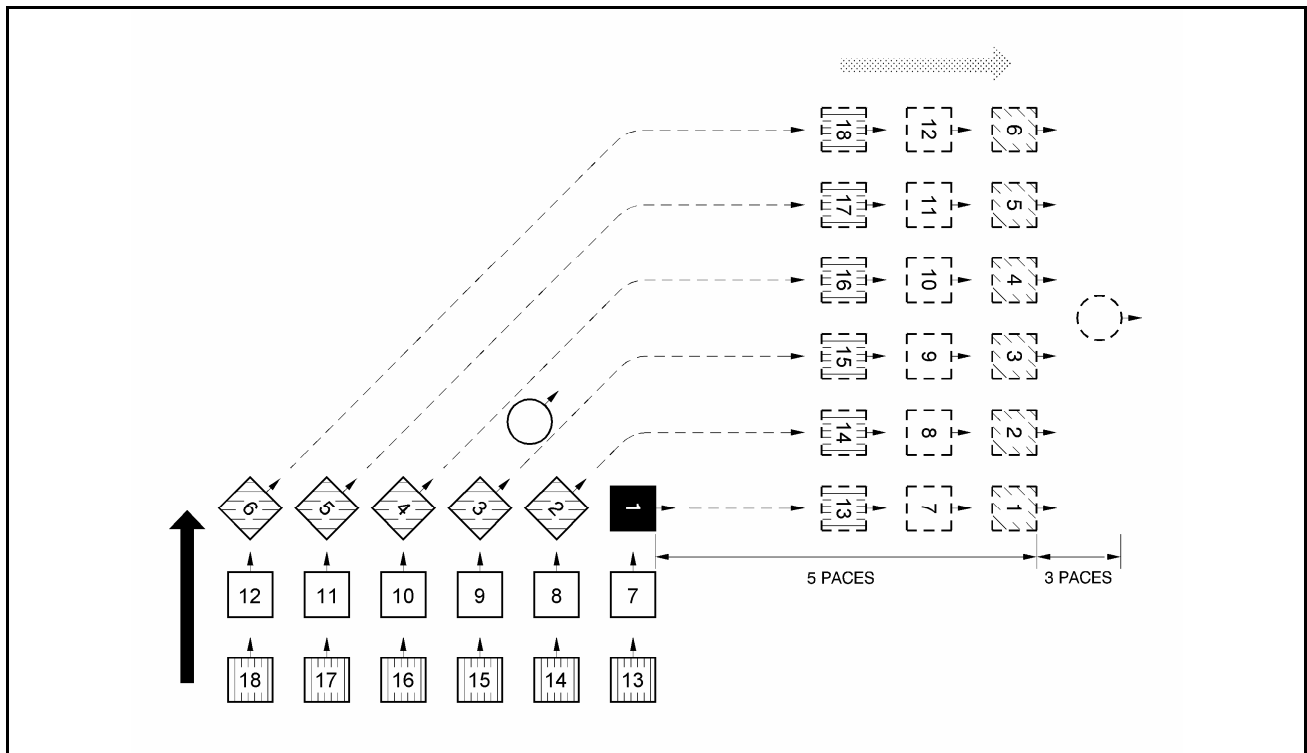

Figure 3-18: Right Form at the Halt

CHANGING DIRECTION BY FORMING ON THE MARCH (OPTIONAL)

159. To change direction by forming on the march to the halt, on the command AT THE HALT, CHANGE DIRECTION RIGHT, RIGHT – FORM, given as the left foot is forward and on the ground:

- (1) the marker executes a right turn on the march, marches forward six paces, then halts
- (2) simultaneously, the squad commander and the remainder of the front rank execute a right incline on the march then wheel toward the new position in line with the right marker
- (3) the centre and rear ranks wheel right to follow the leading individual in each file
- (4) upon reaching its new position each file shall halt together, facing the new direction, in succession from right to left

160. To change direction by forming on the march to the mark time, on the command CHANGE DIRECTION RIGHT, RIGHT – FORM, given as the left foot is forward and on the ground:

- (1) the marker executes a right turn on the march, marches forward six paces, then marks time
- (2) simultaneously, the squad commander and the remainder of the front rank execute a right incline on the march then wheel toward the new position in line with the right marker
- (3) the centre and rear ranks wheel right to follow the leading individual in each file
- (4) upon reaching its new position each file shall mark time together, facing the new direction, in succession from right to left

161. On the command FOR – WARD or SQUAD – HALT, the squad shall act as ordered.

162. Changing direction by forming to the left is executed as for forming to the right except:

- (1) the executive command is given as the right foot is forward and on the ground
- (2) the marker becomes the front-left person
- (3) the marker marches forward five paces and halts or marks time, as appropriate
- (4) the remaining details are reversed so that the form is executed to the left

FORMING SQUAD IN LINE FROM THE HALT (OPTIONAL)

163. Forming a squad in line changes the formation of a squad from threes (twos, single file) to in line while maintaining the squad's facing.

164. To form a squad on its left from the halt to the halt, on the command AT THE HALT, ON THE LEFT, FORM – SQUAD (Figure 3-19):

- (1) the left marker stands fast
- (2) the remainder incline left

165. On the command QUICK – MARCH:

- (1) the left marker marches forward five paces in quick time then halts
- (2) the remainder of the squad steps off, wheeling as necessary, each file taking up its new position to the left of the leading file, facing the same direction and halting together in succession from right to left

166. To form a squad on its left from the halt to the mark time, on the command ON THE LEFT, FORM – SQUAD:

- (1) the left marker stands fast
- (2) the remainder incline left

167. On the command QUICK – MARCH:

- (1) the left marker marches forward five paces in quick time then marks time
- (2) the remainder of the squad steps off, wheeling as necessary, each file taking up its new position to the left of the leading file, facing the same direction and marking time together in succession from right to left

168. On the command FOR – WARD or SQUAD – HALT, the squad shall act as ordered.

169. Forming a squad on the right is executed as for forming on the left except the details are reversed.

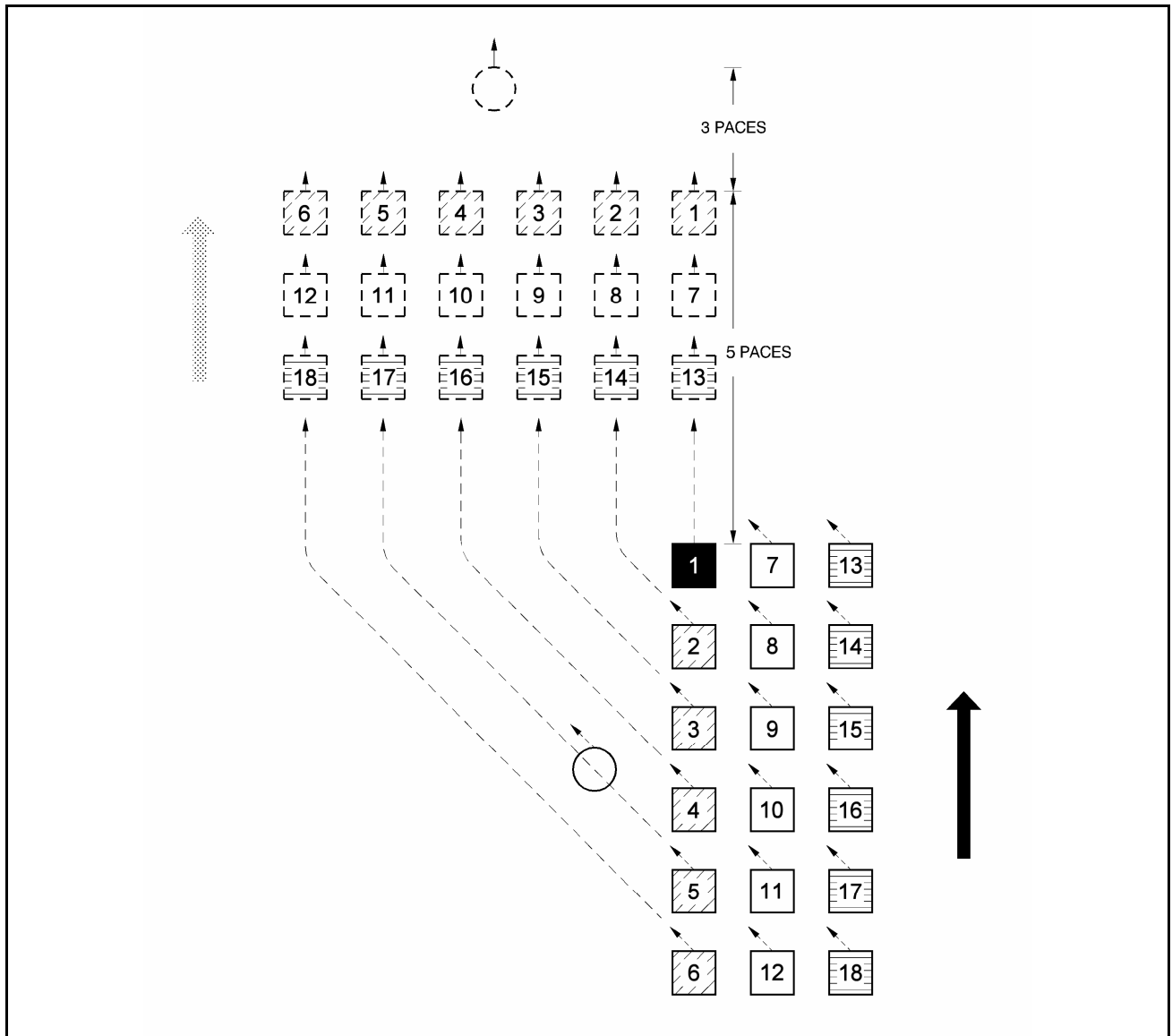

Figure 3-19: Forming Squad in Line from the Halt

FORMING SQUAD IN LINE ON THE MARCH (OPTIONAL)

170. To form a squad on its left on the march to the halt, on the command AT THE HALT, ON THE LEFT, FORM – SQUAD, given as the right foot is forward and on the ground:

- (1) the left marker continues to march forward five paces then halts
- (2) the remainder of the squad executes a left incline on the march, wheels to its position to the left of the leading file, with each file halting together in succession from right to left.

171. To form a squad on its left on the march to the march, on the command ON THE LEFT, FORM – SQUAD, given as the right foot is forward and on the ground:

- (1) the left marker continues to march forward five paces then marks time
- (2) the remainder of the squad executes a left incline on the march, wheels to its position to the left of the leading file, with each file marking time together in succession from right to left

172. On the command FOR – WARD or SQUAD – HALT, the squad shall act as ordered.

173. Changing direction by forming to the right is executed as for forming to the left except:

- (1) the executive command is given as the left foot is forward and on the ground
- (2) the marker becomes the front-right person
- (3) the marker marches forward six paces and halts or marks time, as appropriate
- (4) the remaining details are reversed so that the form is executed to the right

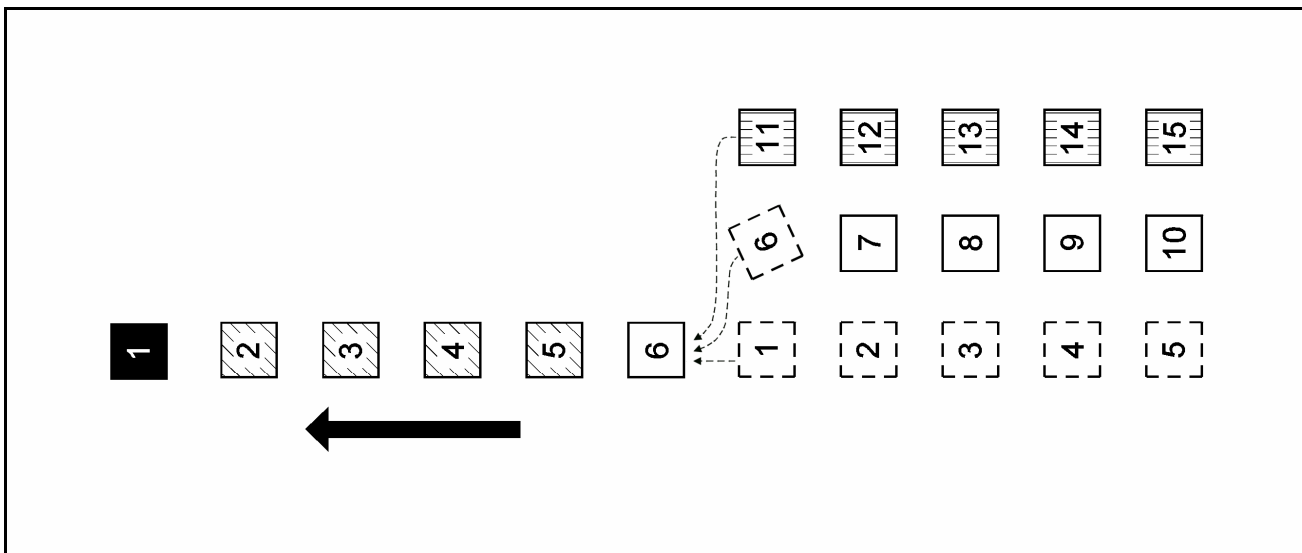

Figure 3-20: Squad in Threes Forming Single File

SQUAD IN THREES OR TWOS FORMING SINGLE FILE FROM THE HALT (OPTIONAL)

174. The command to form single file changes a squad formed in threes or twos into a single continuous file.

175. To form a single file from the halt to the march, on the command SINGLE FILE FROM THE LEFT, QUICK – MARCH (Figure 3-20):

- (1) the directing (left) flank marches off in quick time

- (2) the remainder of the squad mark time. The leading person of each of the remaining files executes a left incline, when the last person of the file to the left is abreast of him, and leads his file in single file behind

176. On the command SINGLE FILE FROM THE RIGHT, QUICK – MARCH, the drill is executed as for forming single file from the left except the directing flank becomes the right flank and the remaining details are reversed so that the squad forms single file from the right.

SQUAD IN THREES OR TWOS FORMING SINGLE FILE ON THE MARCH (OPTIONAL)

177. To form a single file from the march to the march, on the command SINGLE FILE FROM THE LEFT, REMAINDER MARK – TIME, given as the right foot is forward and on the ground:

- (1) the directing (left) flank continues to march forward
- (2) the remainder of the squad mark time. The leading person of each of the remaining files executes a left incline, when the last person of the file to the left is abreast of him, and leads his file in single file behind

178. On the command SINGLE FILE FROM THE RIGHT, REMAINDER MARK – TIME, the drill is executed as for forming single file from the left except the directing flank becomes the right flank and the remaining details are reversed so that the squad forms single file from the right.

SQUAD IN SINGLE FILE REFORMING THREES OR TWOS FROM THE HALT (OPTIONAL)

179. The command to reform threes or twos reforms a squad that was formed into single file into its original formation.

180. To reform threes or twos from the halt to the halt, on the command ON THE RIGHT, REFORM THREES (TWOS), REMAINDER QUICK – MARCH:

- (1) the directing (left) flank stands fast
- (2) the remaining files march to the right of the file on the left and halt when the lead person is abreast of the lead person of the file on the left

181. On the command ON THE LEFT, REFORM THREES (TWOS), REMAINDER QUICK – MARCH, the drill is executed as for a squad in single file reforming on the right except the directing flank becomes the right flank and the remaining details are reversed so that the squad reforms on the left.

SQUAD IN SINGLE FILE REFORMING THREES OR TWOS ON THE MARCH (OPTIONAL)

182. To reform threes or twos from march to the march, on the command ON THE RIGHT, REFORM THREES (TWOS), FRONT RANK MARK – TIME, given as the right foot is forward and on the ground:

- (1) the directing (left) flank marks time
- (2) the remaining files march to the right of the file on the left and mark time when the lead person is abreast of the lead person of the file on the left

183. On the command FOR – WARD or SQUAD – HALT, the squad shall act as ordered.

184. On the command ON THE LEFT, REFORM THREES (TWOS), FRONT RANK MARK – TIME, the drill is executed as for a squad in single file reforming on the right except the directing flank becomes the right flank and the remaining details are reversed so that the squad reforms on the left.

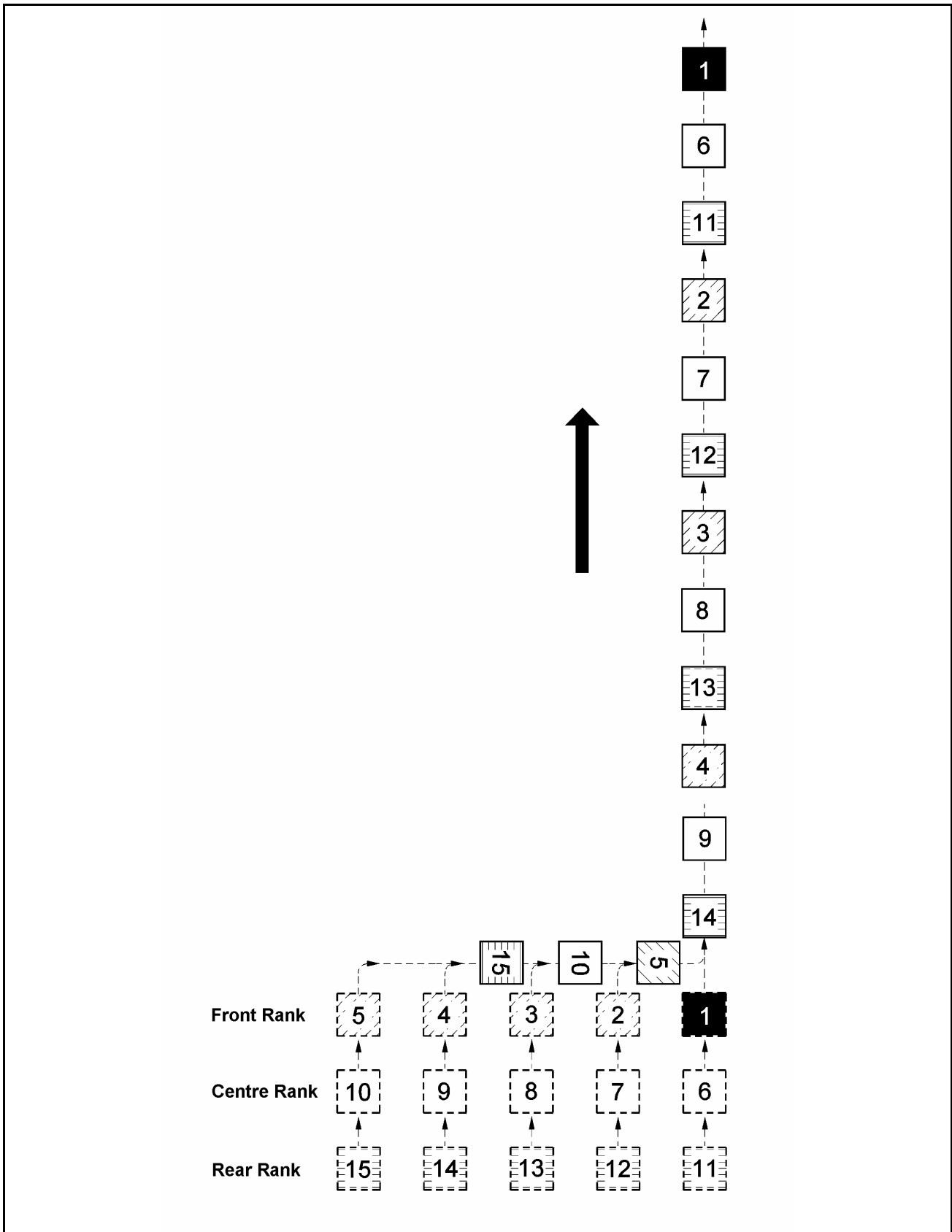

Figure 3-21: Squad in Line Forming Single File

SQUAD IN LINE FORMING SINGLE FILE FROM THE HALT (OPTIONAL)

185. The command to form single file changes a squad formed in line into a single continuous file.

186. To form a single file from the halt to the march, on the command SINGLE FILE FROM THE RIGHT, QUICK – MARCH (Figure 3-21):

- (1) the file on the directing (right) flank marches forward in quick time
- (2) the remainder of the squad mark time then follow the file on the right, wheeling if necessary, when the last person in that file has cleared the formation

187. On the command SINGLE FILE FROM THE LEFT, QUICK – MARCH, the drill is executed as for a squad in single file forming single file from the right except the directing flank becomes the left flank and the remaining details are reversed so that the squad forms single file from the left.

SQUAD IN LINE FORMING SINGLE FILE ON THE MARCH (OPTIONAL)

188. To form a single file from the march to the march, on the command SINGLE FILE FROM THE RIGHT, REMAINDER MARK – TIME, given as the right foot is forward and on the ground:

- (1) the file on the directing (right) flank continues marching forward
- (2) the remainder of the squad mark time then follow the file on the right, wheeling if necessary, when the last person in that file has cleared the formation

189. On the command SINGLE FILE FROM THE LEFT, REMAINDER MARK – TIME, the drill is executed as for a squad in single file forming single file from the right except the directing flank becomes the left flank and the remaining details are reversed so that the squad forms single file from the left.

SQUAD IN SINGLE FILE REFORMING IN LINE FROM THE HALT (OPTIONAL)

190. The command to reform line reforms a squad that was formed into single file into its original formation.

191. To reform in line from the halt to the halt, on the command ON THE LEFT, REFORM LINE, REMAINDER QUICK – MARCH (Figure 3-22):

- (1) the leading file stands fast
- (2) the remainder of the squad march forward in quick time, take up position to the left of the leading file, and halt in succession from right to left

192. On the command ON THE RIGHT, REFORM LINE, REMAINDER QUICK – MARCH, the right the details are reversed so that the remaining files reform on the right of the leading file.

SQUAD IN SINGLE FILE REFORMING IN LINE ON THE MARCH (OPTIONAL)

193. To reform in line from the march to the march, on the command ON THE LEFT, REFORM LINE, REMAINDER MARK – TIME, given as the right foot is forward and on the ground:

- (1) the leading file marks time
- (2) the remainder of the squad march forward in quick time, take up position to the left of the leading file, and mark time in succession from right to left

194. On the command FOR – WARD or SQUAD – HALT, the squad shall act as ordered.

195. For forming on the right, the details are reversed so that the remaining files take up position to the right of the leading file and mark time in succession from left to right.

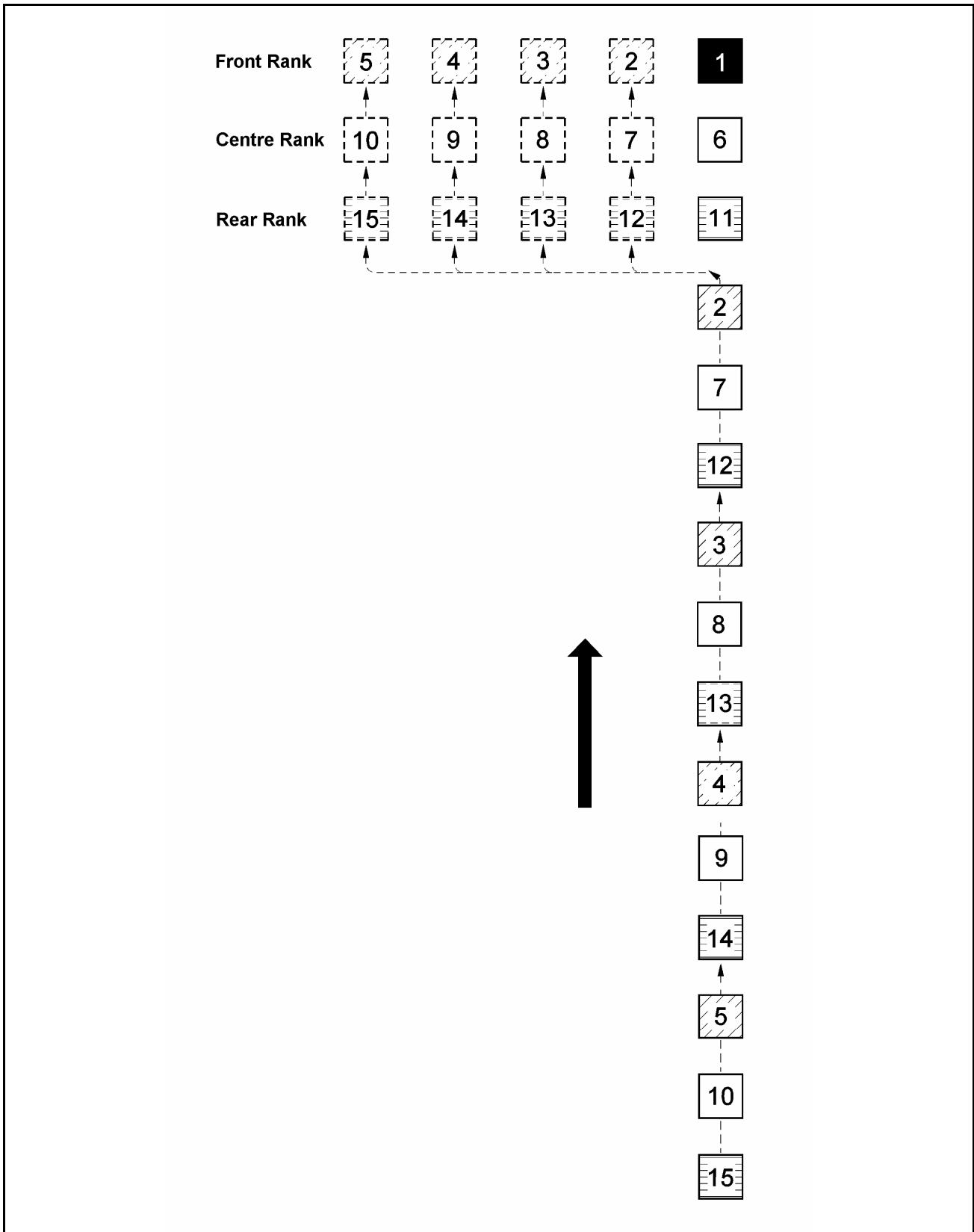

Figure 3-22: Squad in Single File Reforming in Line from the Halt

OPEN ORDER ON THE MARCH IN SLOW TIME (OPTIONAL)

196. On the command OPEN – ORDER, given as the right foot is forward and on the ground, squad members shall act as follows:

- (1) when in two ranks:
 - a. the front rank continues marching forward
 - b. the rear rank marks time for two paces then steps off with the left foot
- (2) when in three ranks:
 - a. the front rank continues marching forward
 - b. the centre rank marks time for two paces
 - c. the rear rank marks time for four paces then steps off with the left foot

CLOSE ORDER ON THE MARCH IN SLOW TIME (OPTIONAL)

197. On the command CLOSE – ORDER, given as the right foot is forward and on the ground, squad members shall act as follows:

- (1) when in two ranks:
 - a. the front rank marks time for two paces then steps off with the left foot
 - b. the rear rank continues marching forward
- (2) when in three ranks:
 - a. the front rank mark time for four paces
 - b. the centre rank mark time for two paces
 - c. the rear rank continues marching forward

THIS PAGE INTENTIONALLY BLANK

CHAPTER 4
COLOUR DRILL

GENERAL

1. Colour drill is executed with a standard pause between movements similar to drill at the halt and drill on the march.
2. The colour belt is worn over the left shoulder with the socket in the centre of the body at groin height.

POSITION OF THE ORDER

3. The position of the order is as follows (Figure 4-1):
 - (1) the colour bearer is at attention
 - (2) the pike is vertical with the base of the pike on the ground and in line with the toe of the right foot
 - (3) the Colour is held tightly against the pike with the right hand encircling the pike and Colour, at the point of the pike where the lowest corner of the Colour hangs, with the wrist directly behind the pike and the right elbow pressed into the side of the body
 - (4) the Colour hangs naturally and is not stretched taut

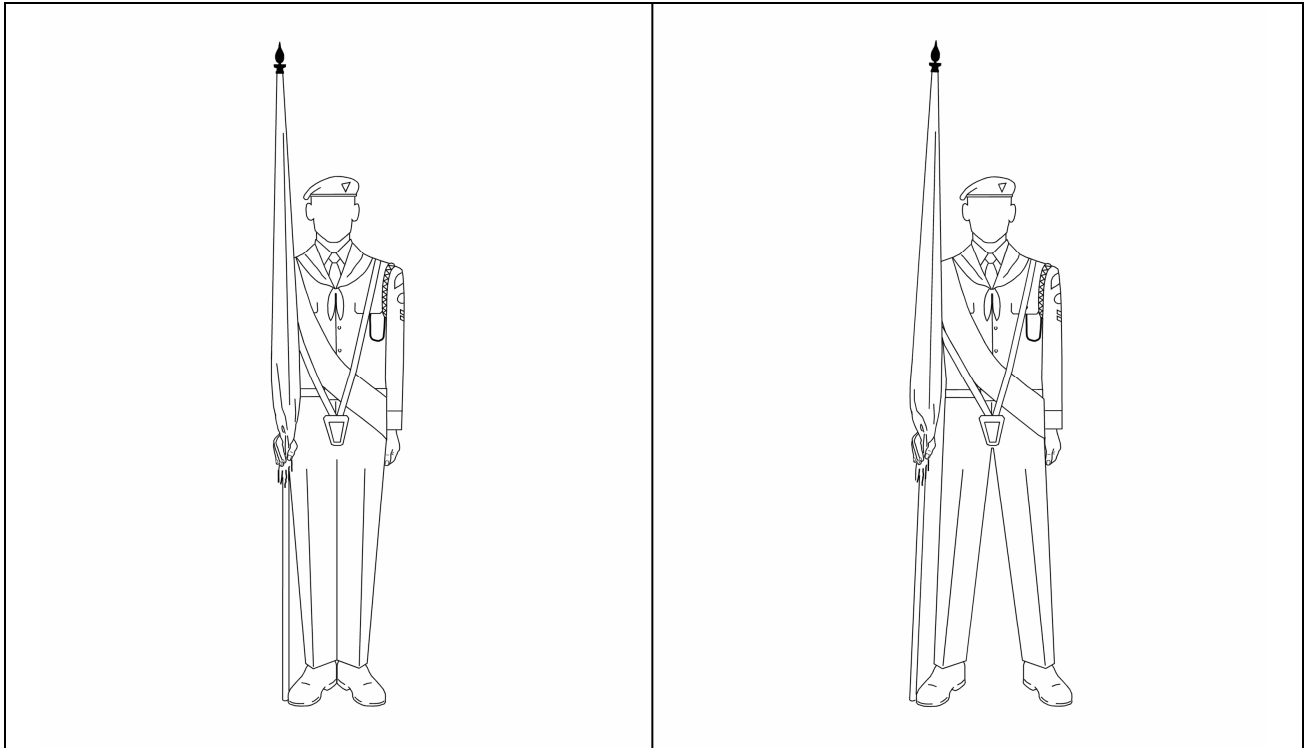

Figure 4-1: Position of the Order

Figure 4-2: Stand at Ease from the Order

STAND AT EASE FROM THE ORDER

4. On the command STAND AT – EASE, the colour bearer shall move his left foot smartly to the position of standing at ease, keeping the left arm at the side and maintaining the pike and Colour in the position of the order (Figure 4-2).

STAND EASY FROM STAND AT EASE

5. On the command STAND – EASY, the colour bearer is permitted to relax but shall not move either his feet or the pike and Colour.

STAND AT EASE FROM STAND EASY

6. On the cautionary command SQUAD, COLOUR PARTY, etc., the colour bearer shall immediately assume the position of stand at ease.

ORDER FROM STAND AT EASE

7. On the command ATTEN – TION, the colour bearer shall move his left foot smartly to the position of attention.

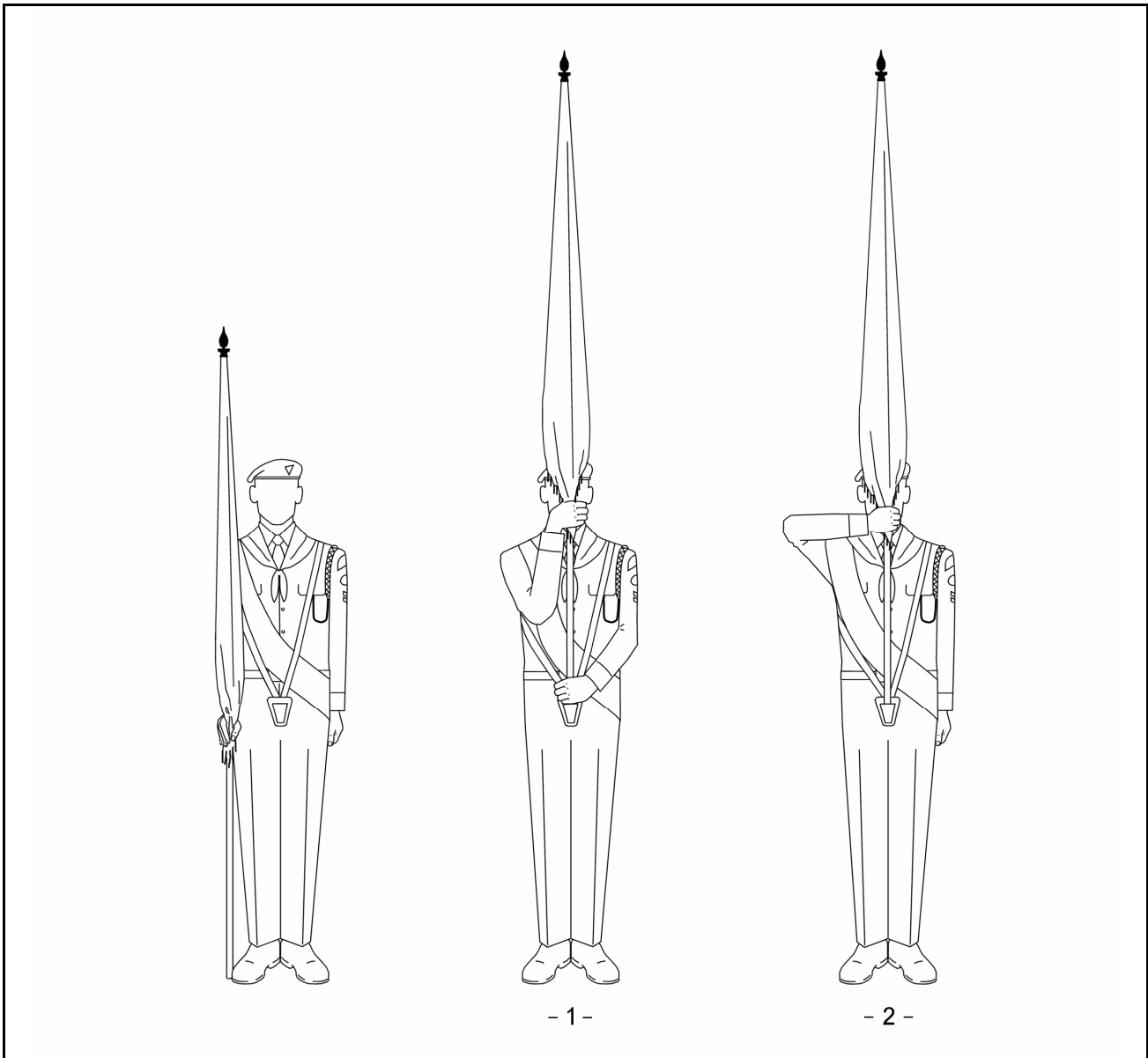

Figure 4-3: Carry from the Order

CARRY FROM THE ORDER

8. Due to the fatigue it can induce over long periods, the carry is used only during the most important parts of ceremonial events such as salutes, inspections, march-pasts, and marching the Colours on and off parade.
9. On the command CARRY COLOUR(S) BY NUMBERS, SQUAD – ONE, the colour bearer shall (Figure 4-3):
- (1) raise the Colour to a vertical position in the front and centre of the body, keeping the right forearm alongside the pike and the base of the pike just above the socket of the colour belt
 - (2) simultaneously, bring the left hand up and, using the left hand to guide the base, insert the pike into the socket
10. On the command SQUAD – TWO:
- (1) drop the left hand smartly to the side as for the position of attention
 - (2) simultaneously, raise the right elbow so that the forearm is parallel to the ground
 - (3) on completion of the movement:
 - a. the pike is held vertical with the right hand opposite the mouth, wrist straight and back of the hand outwards
 - b. the head and eyes face the front
11. On the command CARRY – COLOUR(S), the two movements are combined with a standard pause between each movement.

ORDER FROM THE CARRY

12. On the command ORDER COLOUR(S) BY NUMBERS, SQUAD – ONE, the colour bearer shall (Figure 4-4):
- (1) raise the base of the pike just clear of the socket, dropping the right forearm to a vertical position alongside the pike
 - (2) simultaneously, bring the left hand up and grasp the base of the pike to steady the pike and belt
13. On the command SQUAD – TWO:
- (1) move the pike to the right side of the body while steadying it with both hands
 - (2) lower the pike to the position of the order with the right hand while letting it slide between the fingers of the left hand
 - (3) as the base of the pike touches the ground, adjust the position of the left forearm so that the forearm is parallel to the ground while simultaneously straightening the fingers of the left hand
14. On the command SQUAD – THREE, drop the left arm smartly to the side as for the position of attention.
15. On the command ORDER – COLOUR(S), the three movements are combined with a standard pause between each movement.

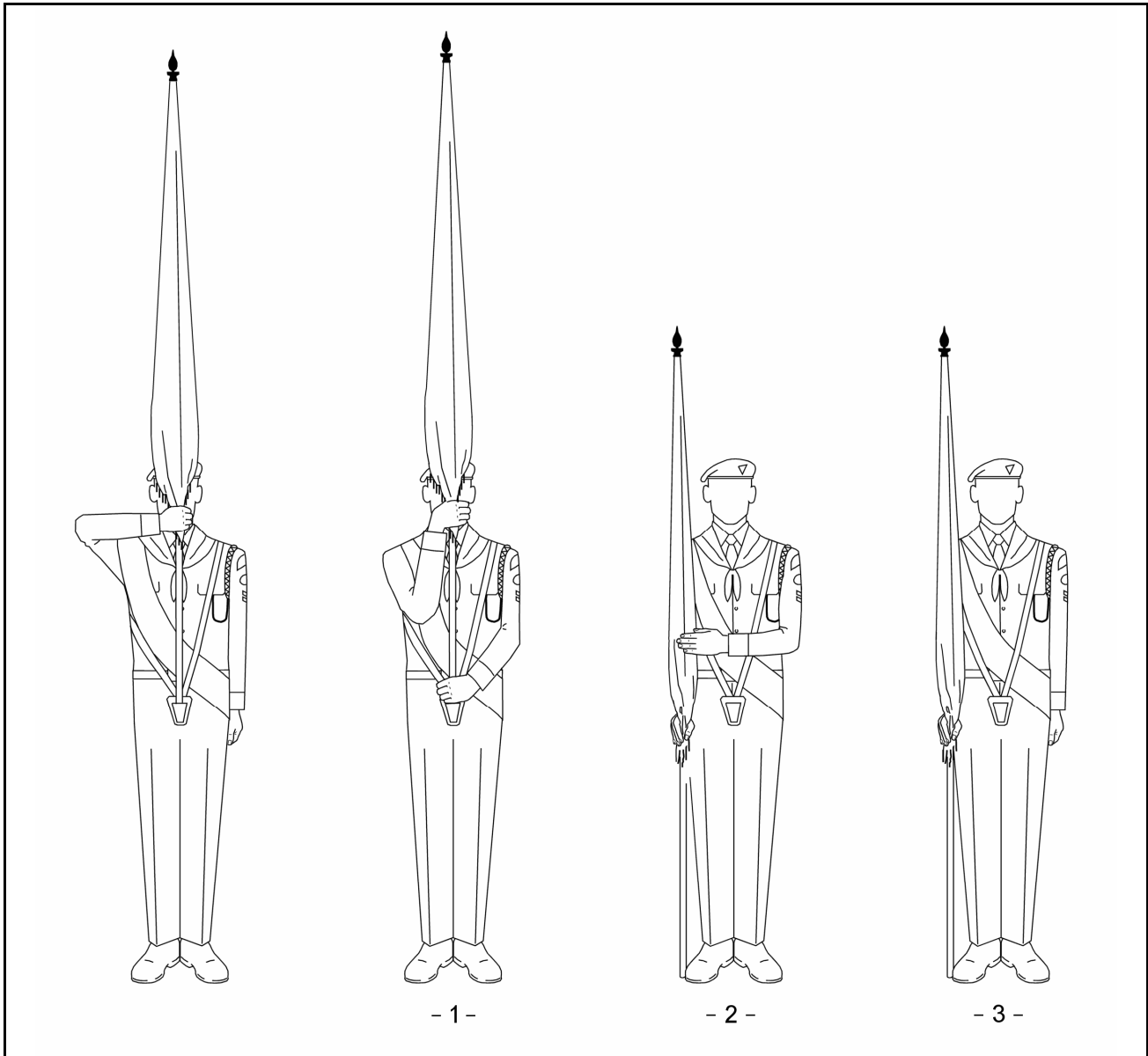

Figure 4-4: Order from the Carry

LET FLY FROM THE CARRY

- 16. Letting fly the Colour is used as a method of paying compliments or when it is desirable to allow a Colour to be freely recognised.
- 17. On the command LET FLY THE – COLOUR(S), the colour bearer shall slide the right hand sharply down the pike until the corner of the Colour slips free of the hand (Figure 4-5).
- 18. During a march past in quick time, on the command EYES – RIGHT, the Colour is let fly the next time the left foot strikes the ground; i.e., the same moment as the head and eyes are turned to the right.

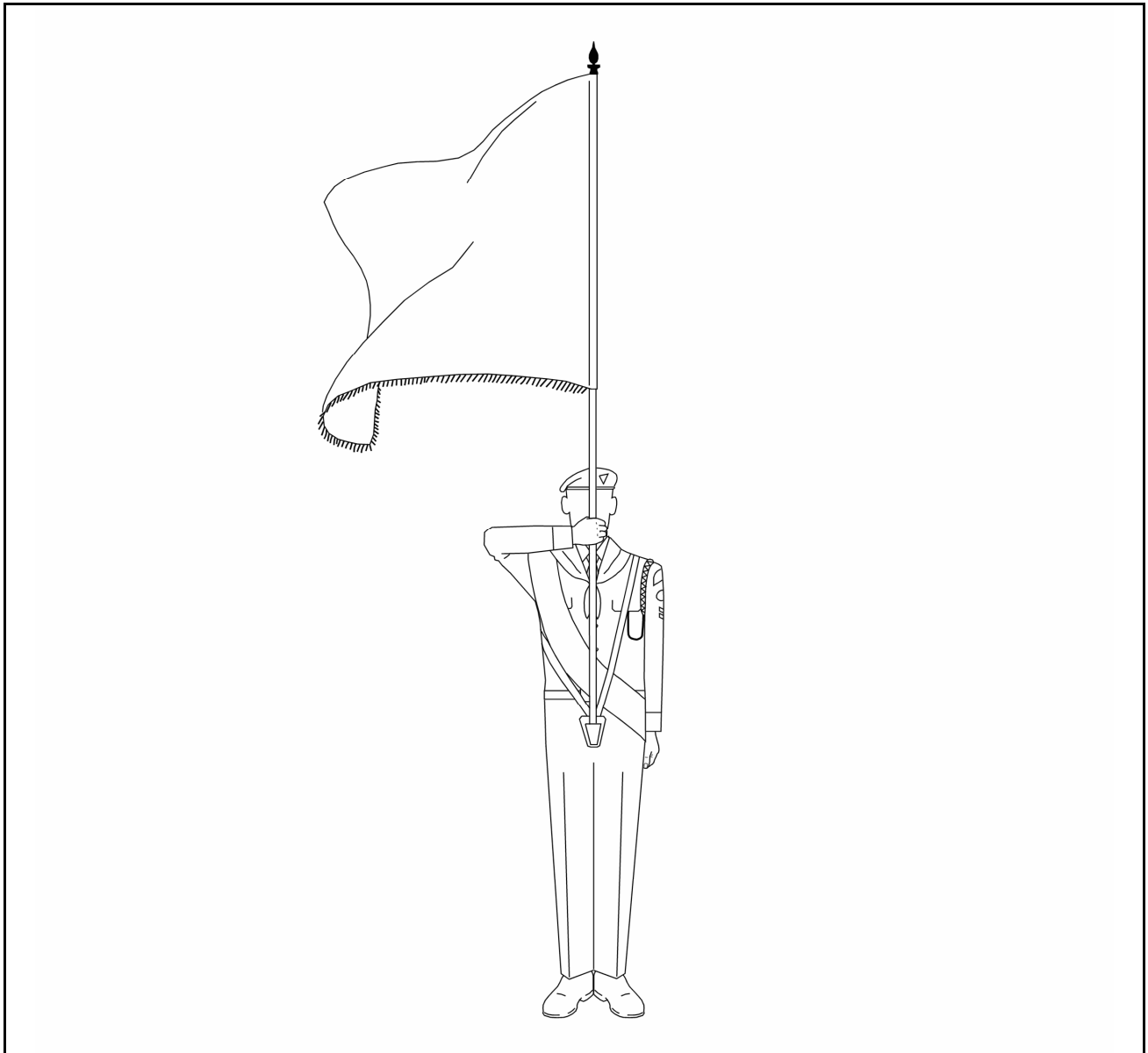

Figure 4-5: Let Fly from the Carry

CATCH FROM THE LET FLY

19. On the command CATCH THE COLOUR(S) BY NUMBERS, SQUAD – ONE, the colour bearer shall (Figure 4-6):

- (1) reach out and grab the Colour with the left hand, bringing it into the pike
- (2) when the left hand reaches the pike, grasp the lower corner of the Colour with the right hand, the hand encircling both the pike and Colour, with back of the hand outwards and right forearm alongside the pike

20. On the command SQUAD – TWO:

- (1) drop the left arm smartly to the side as for the position of attention
- (2) simultaneously, raise the right forearm parallel to the ground

21. On the command CATCH THE – COLOUR(S), the two movements are combined with a standard pause between each movement.

22. If wind direction makes it difficult to catch the Colour with the left hand, the left hand is used instead to hold the pike while the Colour is caught and brought into the pike with the right hand. If, because of wind strength the Colour cannot be caught, the Colour shall be lowered to the position of the order, the Colour secured and then returned to the carry. While on the march the base of the pike shall held just clear of the ground while securing the Colour.

23. During a march past in quick time, on the command EYES – FRONT, the Colour is caught the next time the left foot strikes the ground; i.e., the same moment as the head and eyes are turned to the front.

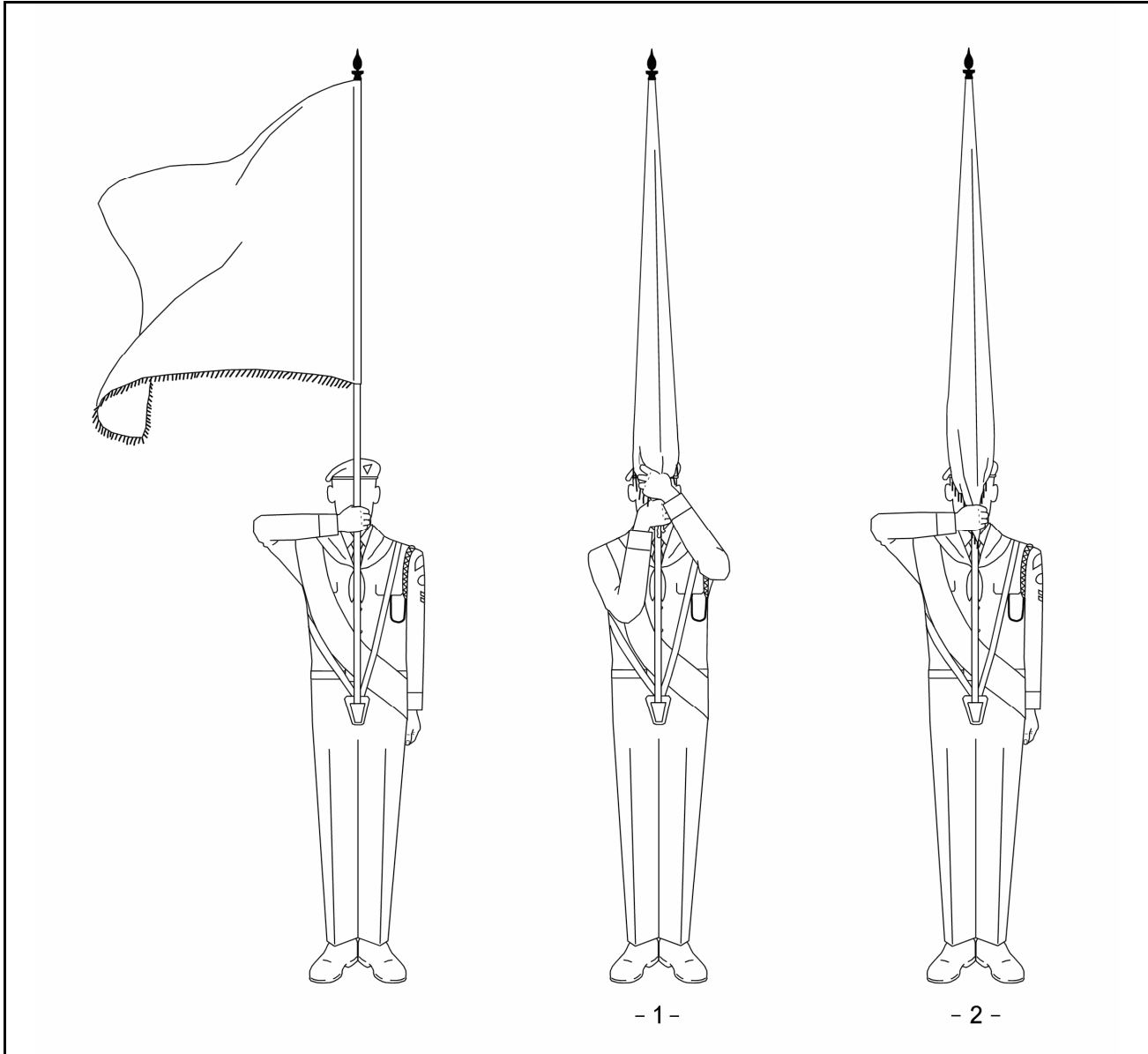

Figure 4-6: Catch from the Let Fly

SLOPE FROM THE CARRY

24. The slope is the normal position for carrying Colours.

25. On the command SLOPE COLOURS BY NUMBERS, SQUAD – ONE, the colour bearer shall (Figure 4-7):

- (1) with the right hand raise the pike clear of the socket, dropping the elbow so that the right forearm is alongside the pike
- (2) simultaneously, bring the left hand up and grasp the base of the pike to steady the pike and belt

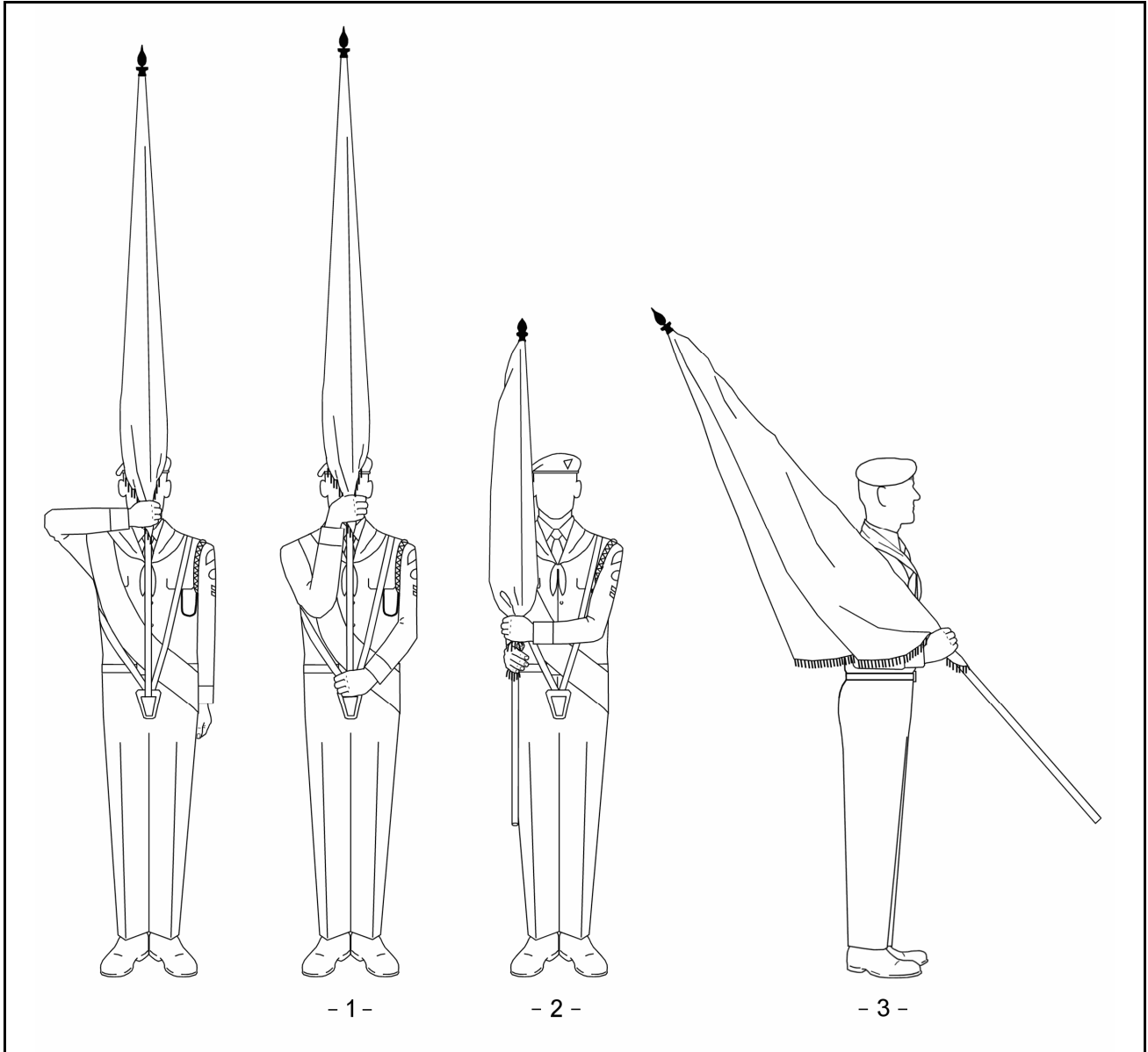

Figure 4-7: Slope from the Carry

26. On the command SQUAD – TWO:

- (1) lower the pike and Colour to the right shoulder with the right hand
- (2) simultaneously, with the left hand grasp the pike above the right hand to steady the pike

(3) on completion of the movement:

- a. the right forearm shall be parallel to the ground with the elbow pressed into the side of the body
- b. the pike shall be at a 45 degree angle on the right shoulder with the Colour covering the right shoulder, arm and the pike

27. On the command SQUAD – THREE, drop the left arm smartly to the side as for the position of attention.

28. On the command SLOPE – COLOUR(S), the three movements are combined with a standard pause between each movement.

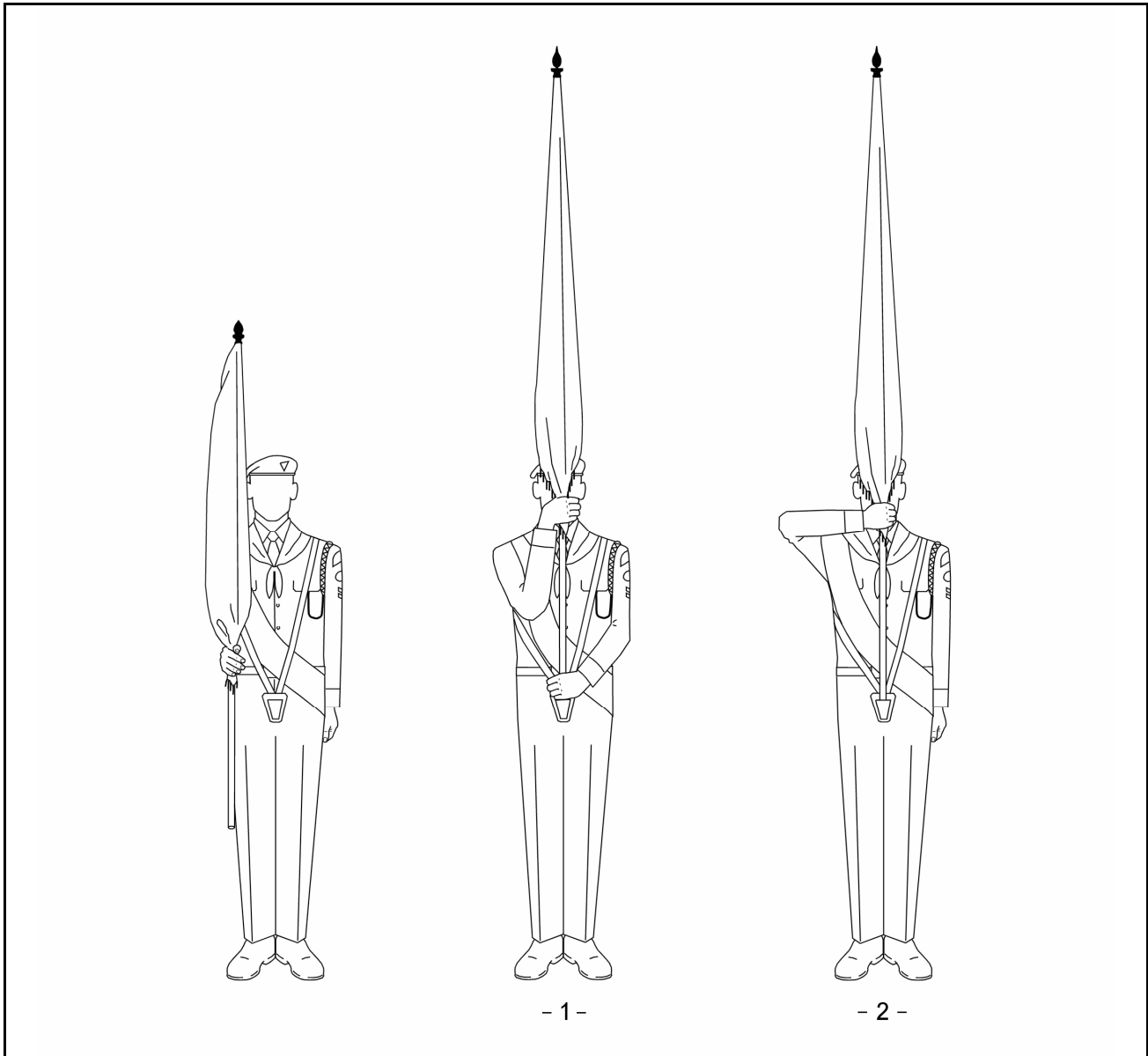

Figure 4-8: Carry from the Slope

CARRY FROM THE SLOPE

29. On the command CARRY COLOUR(S) BY NUMBERS, SQUAD – ONE, the colour bearer shall (Figure 4-8):

- (1) with the right hand raise the pike to a vertical position, base of the pike just above the socket
- (2) simultaneously, bring the left hand up and, using the left hand to guide the base, insert the pike into the socket

30. On the command SQUAD – TWO, drop the left arm smartly to the side as for the position of attention.

31. On the command CARRY – COLOUR(S), the two movements are combined with a standard pause between each movement.

THIS PAGE INTENTIONALLY BLANK

GLOSSARY

Advance	To turn, or move, toward the front.
Cadence	The number of paces per minute.
Colour	A flag or banner used to identify a nation, group, or organisation.
Cover	An act by which an individual in a formation places himself directly behind another within a file.
Dressing	The vertical and horizontal alignment of the ranks and files of a formation.
File	A subgroup of personnel formed up and aligned one behind another as part of a larger formation such as a squad or platoon.
File, blank	A spot in a file that is unoccupied by personnel.
File, single	A formation composed of one line of personnel arranged one behind another.
Flank	The side of a formation. A formation has only two flanks, the left flank and the right flank.
Flank, directing	The flank by which a formation takes its dressing. The directing flank is normally the side on which the marker is located.
Flank, inner	The directing flank serving as a pivot when a formation changes direction.
Flank, outer	The flank opposite the inner flank.
Form	A movement by which a formation changes direction without changing the shape of the formation.
Form squad	A movement by which a formation changes shape without changing direction.
Formation	A generic term for an organised body of personnel; e.g., squad, platoon. A formation can contain one, two, or three ranks.
Front	The direction a formation faces. The front remains the same from the time a formation falls in until the formation is dismissed.
Half pace	A pace of 35 cm. (approximately 14 inches) as measured from the heel of the rear foot to the heel of the front foot.
Incline	To change direction by 45 degrees.
Interval	The distance between adjacent ranks or adjacent files.
Left	The direction to the left of a formation. The left remains the same from the time a formation falls in until the formation is dismissed.
Marker	A designated individual, usually the number one person of the front rank, from whom all other personnel in the formation take their dressing.
Mark time	To march in one spot.
Move to the left	To turn, or move, toward the left.
Move to the right	To turn, or move, toward the right.

Pace	A standard stride of 75 cm. (approximately 30 inches) as measured from the heel of the rear foot to the heel of the front foot.
Parade (verb)	To formally assemble on a parade ground for drill and ceremonial.
Parade (noun)	The sum of all units assembled on a parade ground for drill and ceremonial
Pay compliments	Render a salute to entitled persons or parties.
Pike	The pole on which Colours or other flags are mounted for carrying or display.
Platoon	A body of personnel formed up on parade.
Rank	A group of personnel formed up and aligned in line abreast, usually as part of a larger formation such as a squad or platoon.
Rear	The direction behind a formation. The rear remains the same from the time a formation falls in until the formation is dismissed.
Retire	To turn, or move, toward the rear.
Right	The direction to the right of a formation. The right remains the same from the time a formation falls in until the formation is dismissed.
Squad	A body of personnel formed up for the purpose of receiving drill instruction.
Stand fast	To remain in position; to not move.
Standard pace	A pace of 75 cm. (approximately 30 inches) as measured from the heel of the rear foot to the heel of the front foot.
Turn	To change direction by 90 degrees. A turn executed by a formation will change both the direction and shape of the formation.
Wheel	A movement whereby a formation changes direction, usually by 90 degrees, without changing the shape of the formation.